

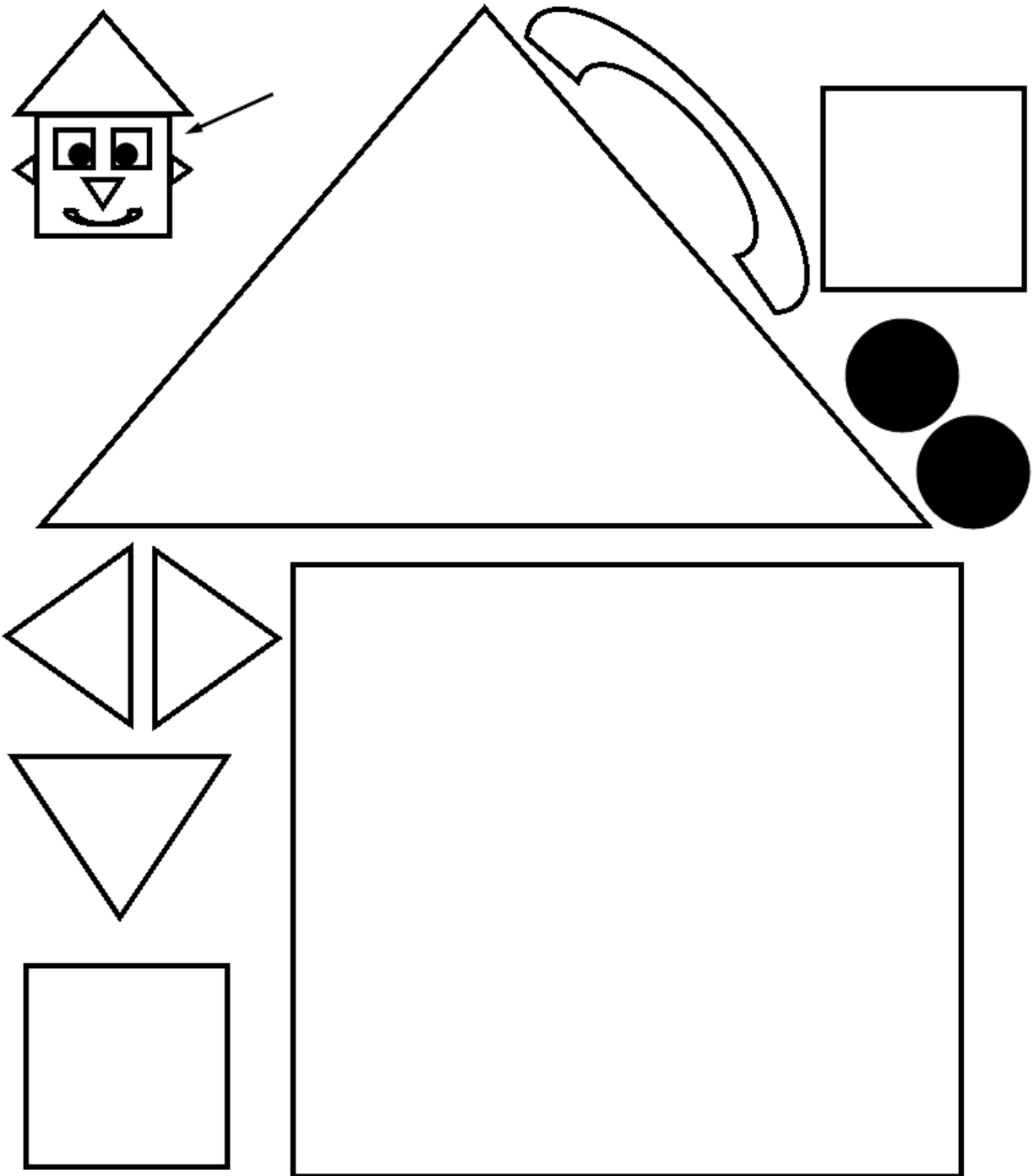

Grade 1 Warm up

Student's Name

Colour. Cut out. Paste to another paper.





Grade 1 Warm up

Student's Name

Follow and draw.

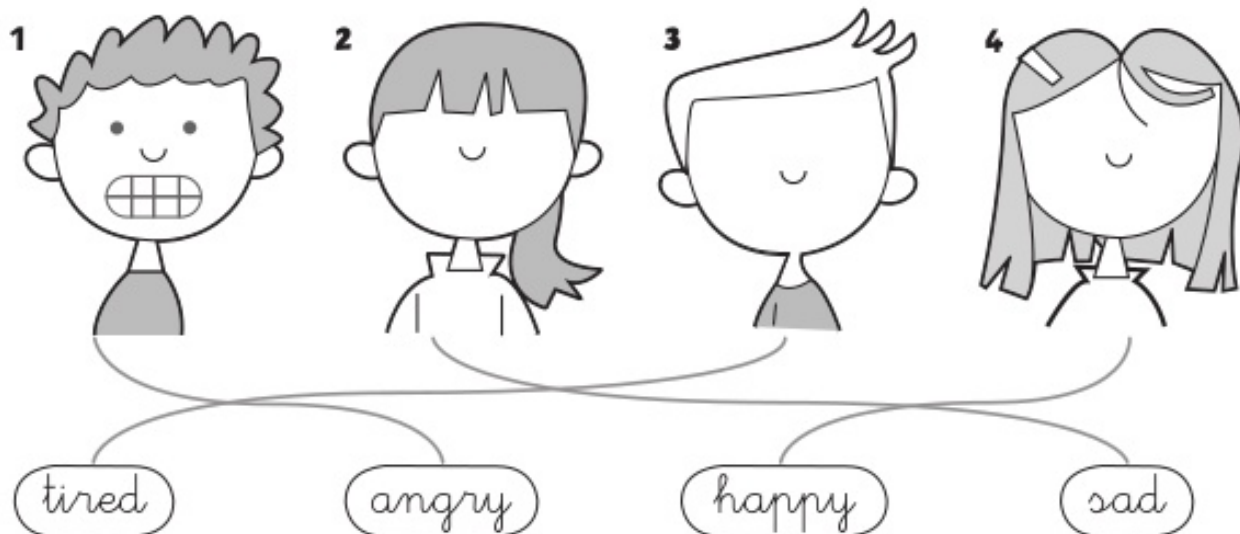
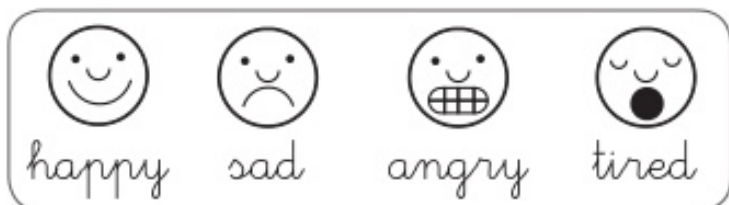

Match and write.

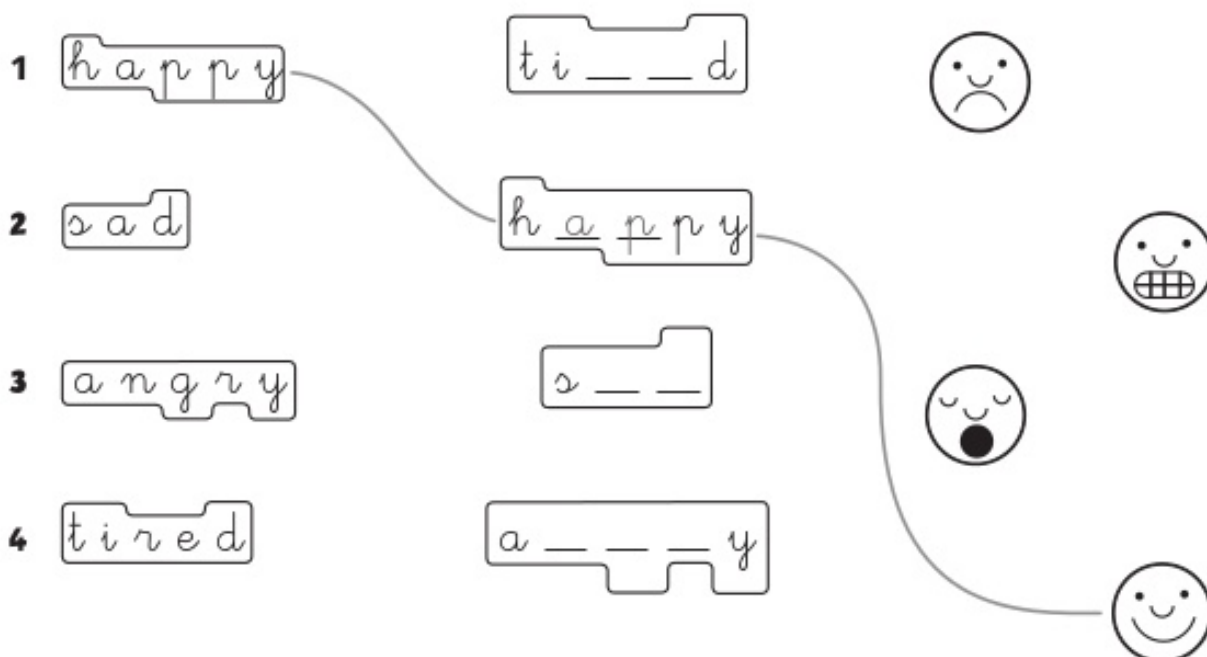



Grade 1 Warm up

Student's Name

Join each letter to the picture with same beginning sound.

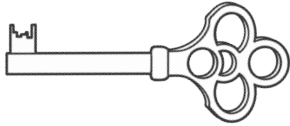

B



A

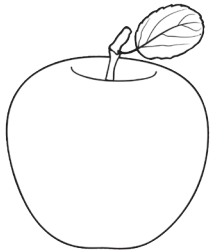

E

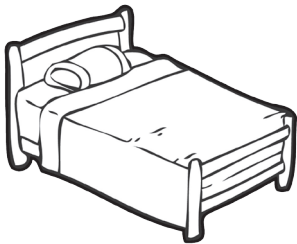

C

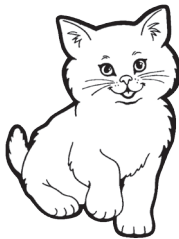

K

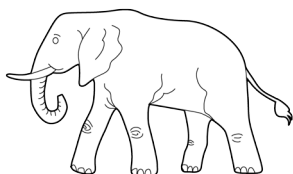

H



Grade 1 Warm up

Student's Name

Connect the dots.

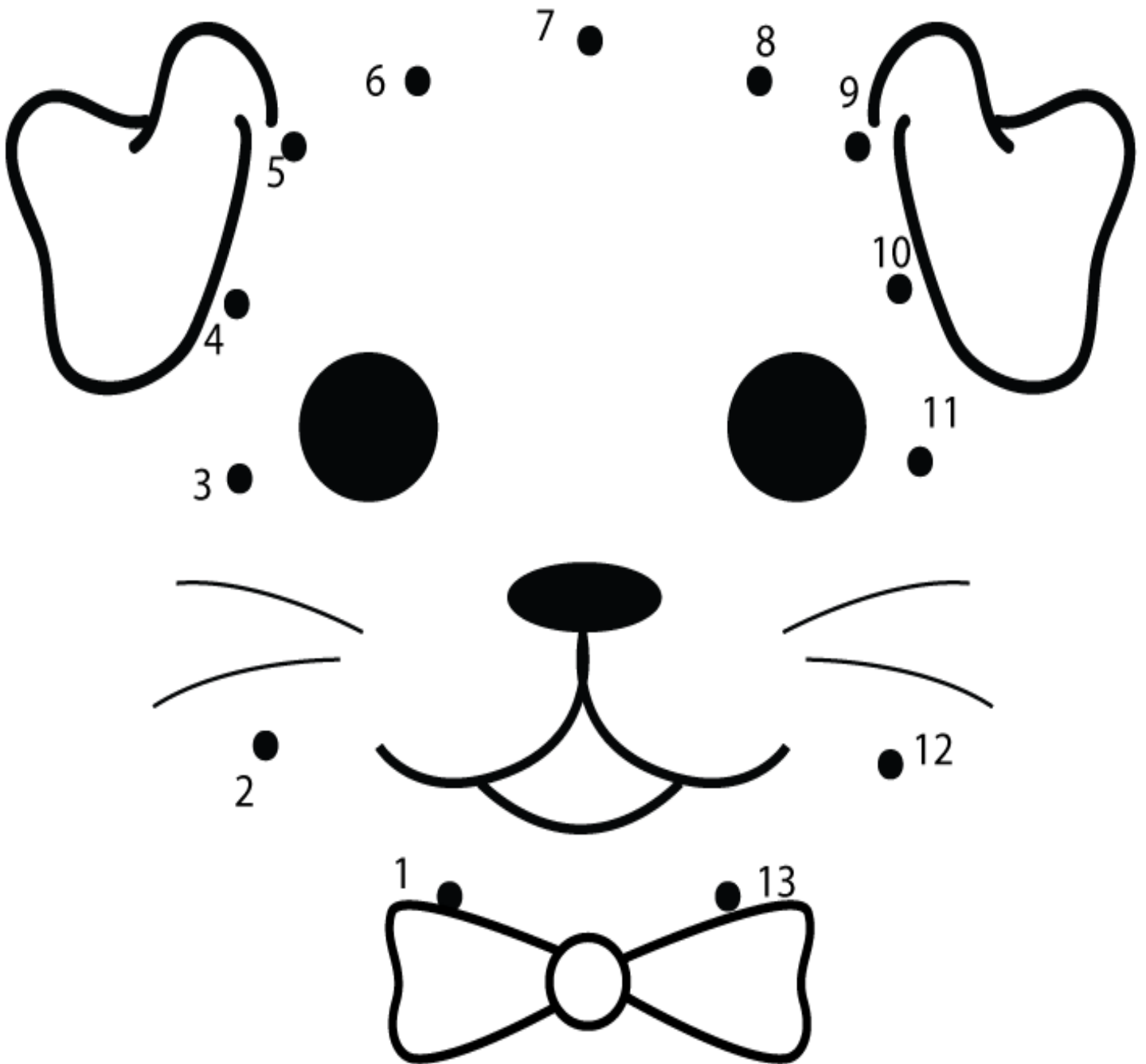



Grade 1 Warm up

Student's Name

Draw a line to connect each picture with its other half.

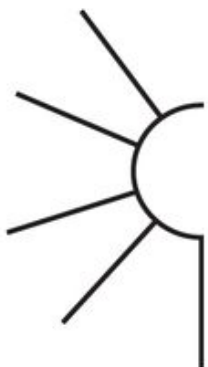
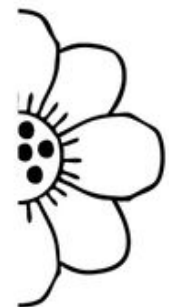
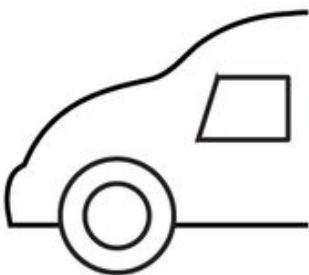
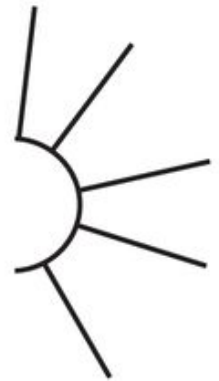
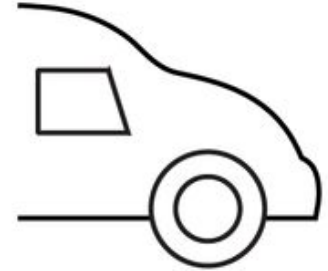



Gradel Warm up

Student's Name

Colour by numbers.

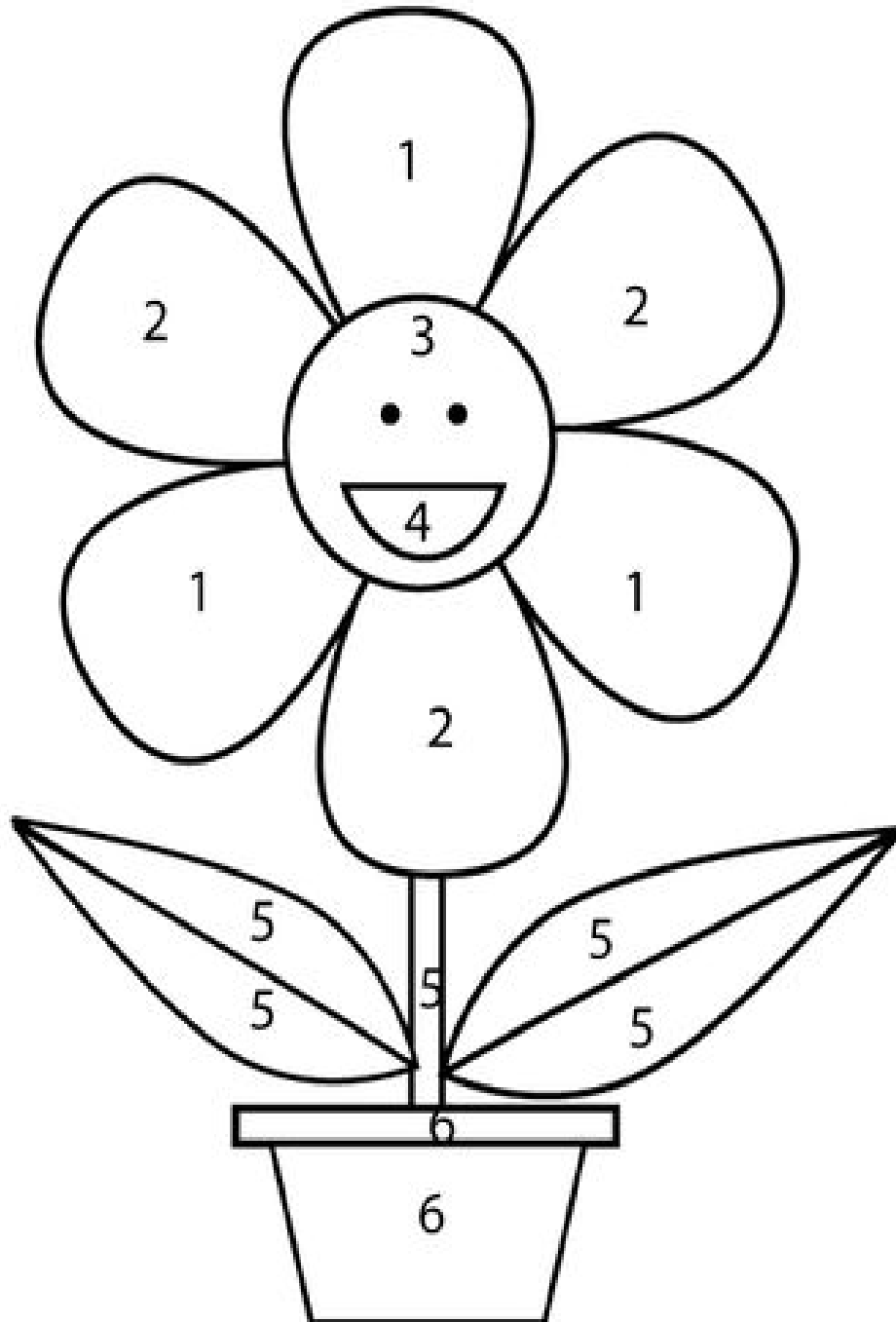

1- red, 2 - orange, 3 - yellow, 4 - pink, 5 - green, 6 - brown



Grade 1 Warm up

Student's Name

Draw the shapes in the same sequence and colour the train.

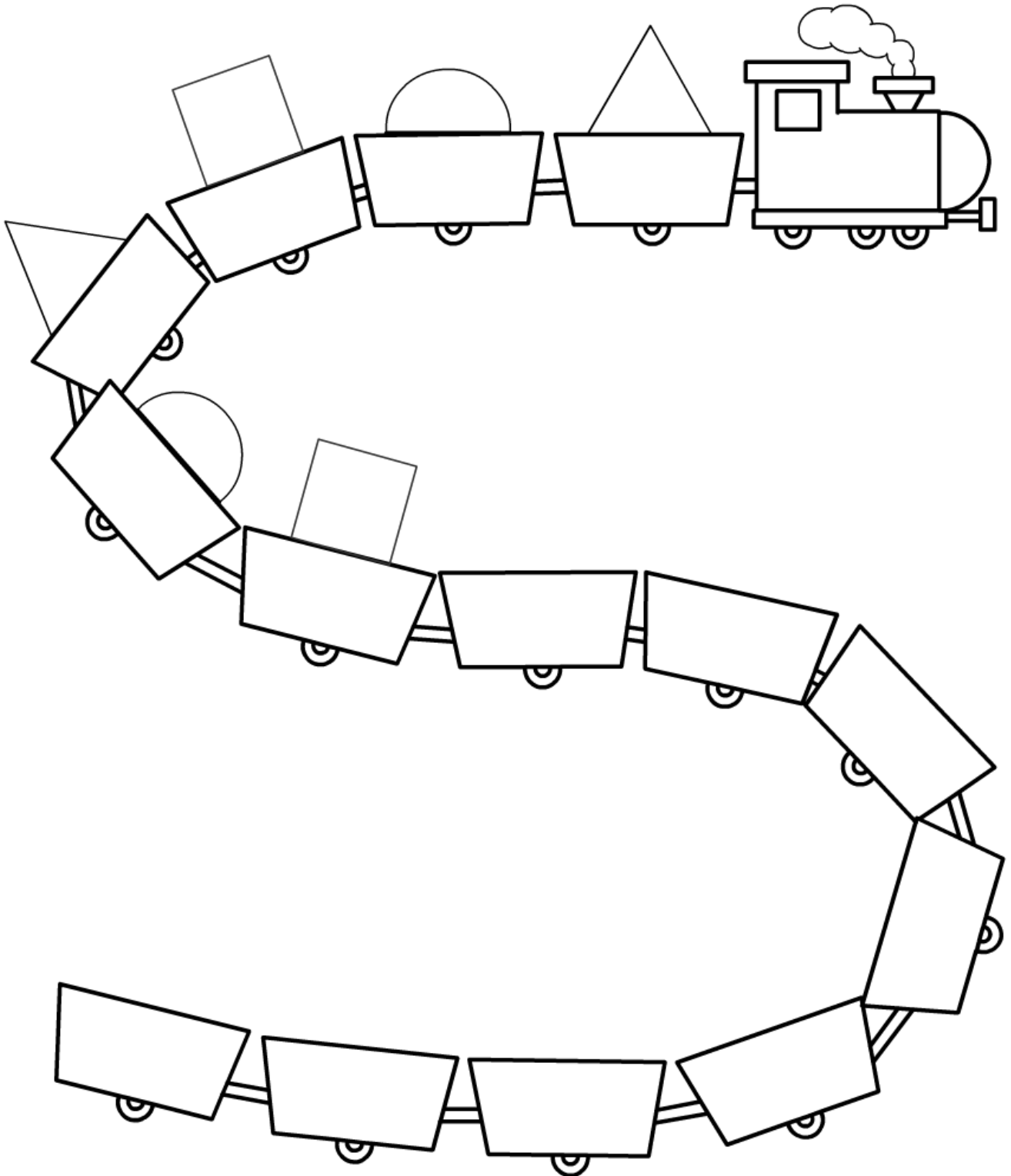



Grade 1 Warm up

Student's Name

Solve the maze.

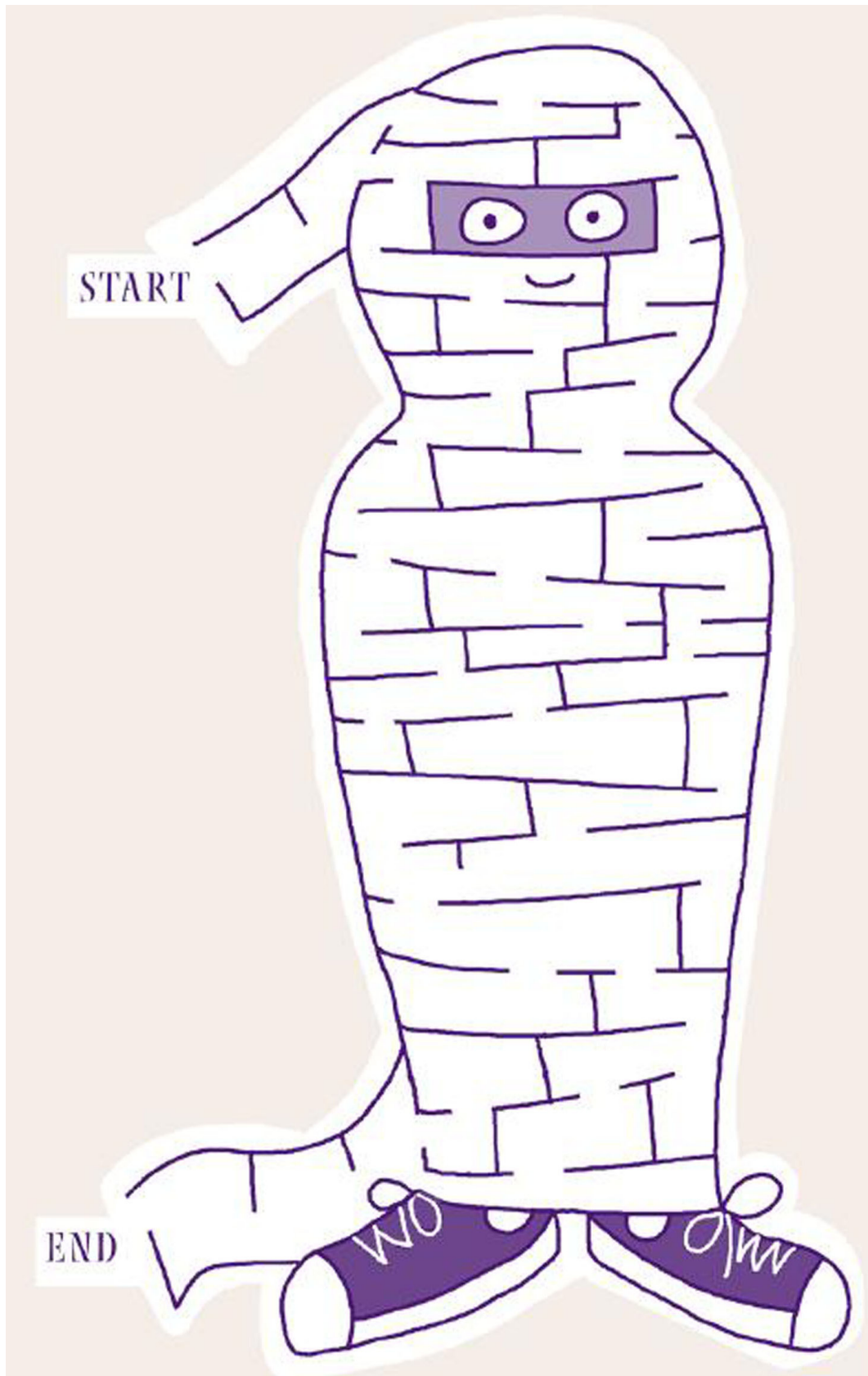



Grade 1 Warm up

Student's Name

Follow the lines with your pencil.

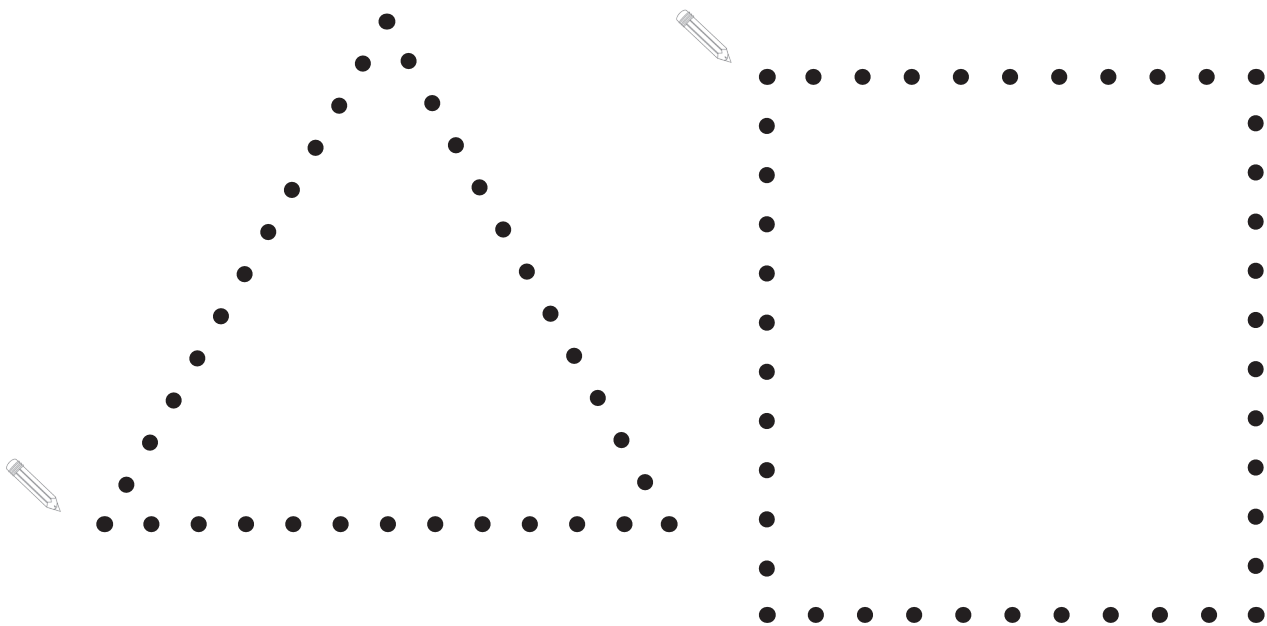
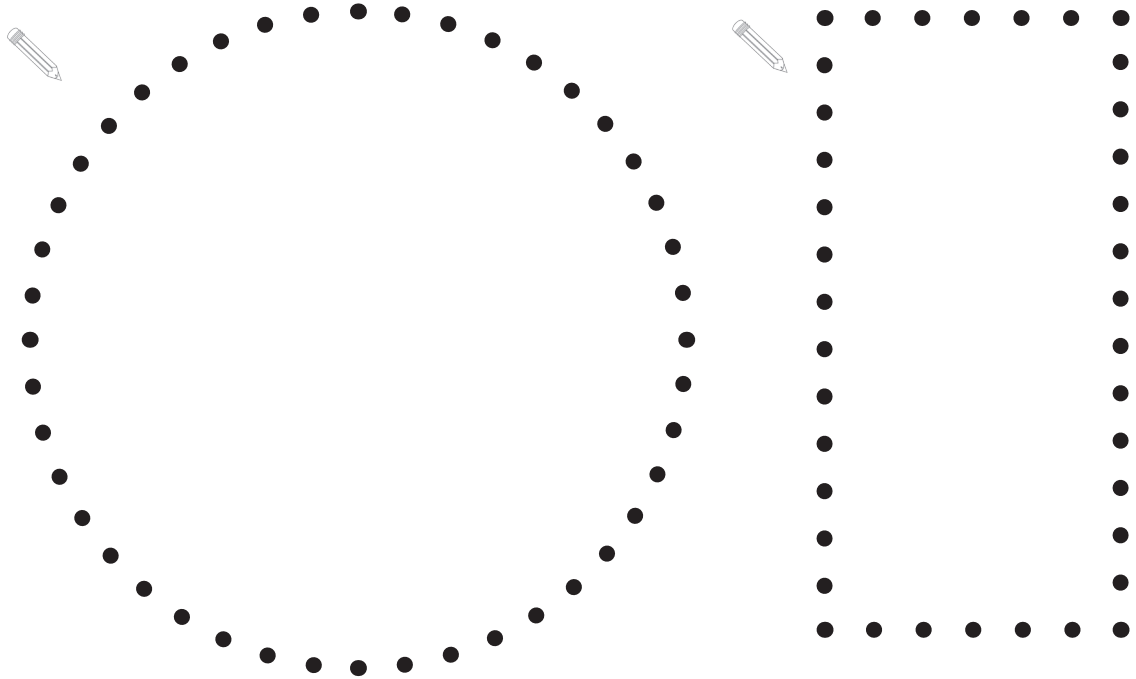



Grade 1 Warm up

Student's Name

Draw the other side.

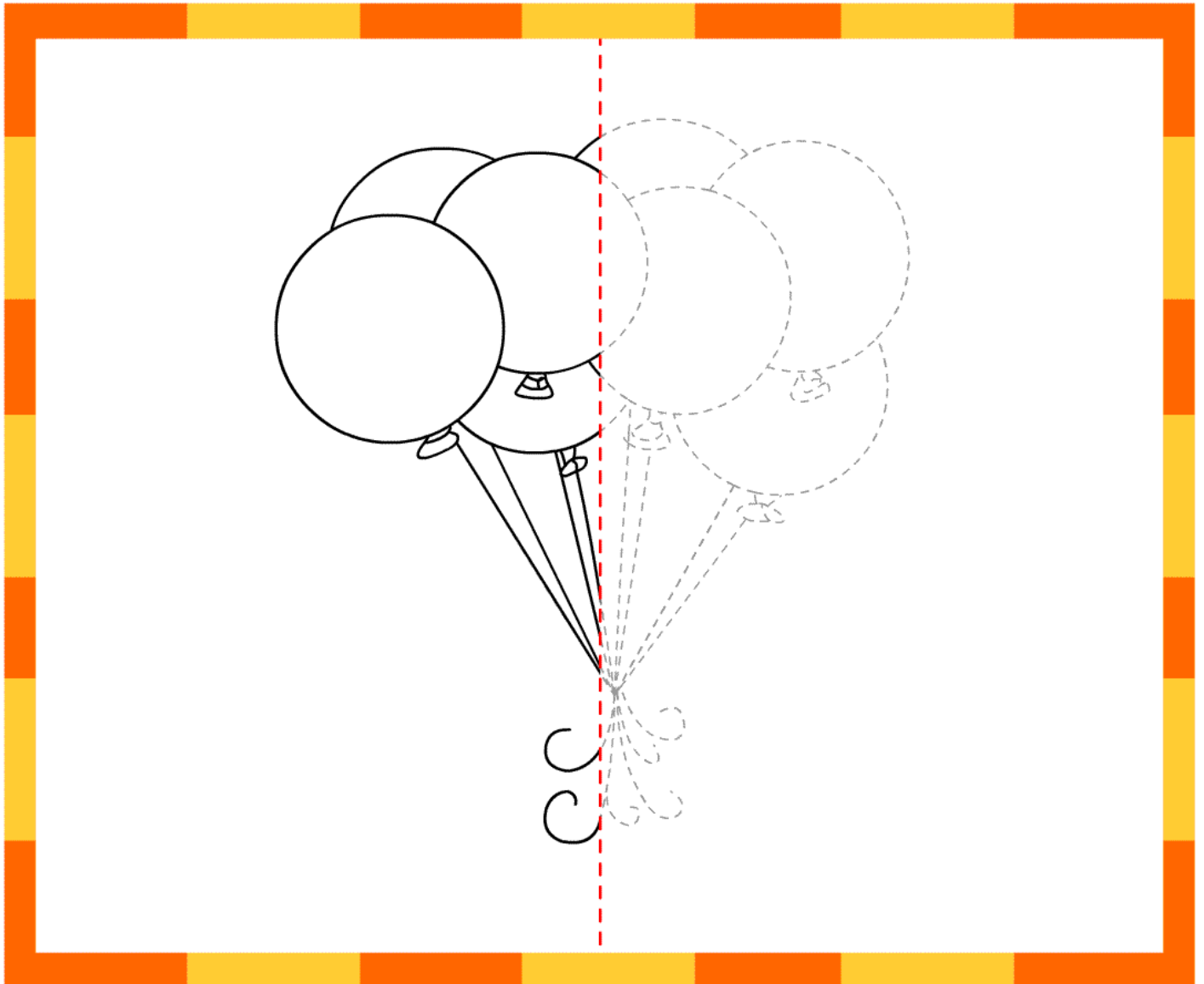

























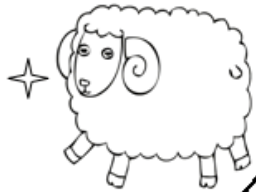

Grade 1 Warm up

Student's Name

Match the animals.

monkey		☆		☆	
giraffe		☆		☆	
chicken		☆		☆	
dog		☆		☆	
lion		☆		☆	
cat		☆		☆	
rabbit		☆		☆	
cow		☆			
snake		☆			
horse		☆			
sheep		☆			
spider		☆			



Grade 1 Warm up

Student's Name

Cutting skills.

This section contains eight rows of dashed curved lines for cutting practice. Each row starts with a scissors icon on the left, indicating the starting point and direction for cutting. The lines are arranged in a descending staircase pattern from top-left to bottom-right.



Count and trace.

Count and Trace

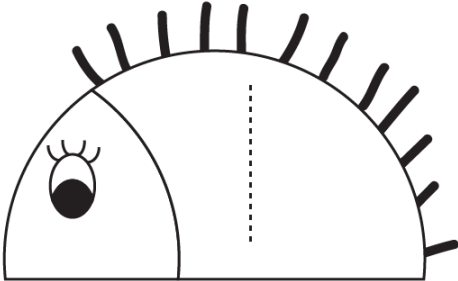
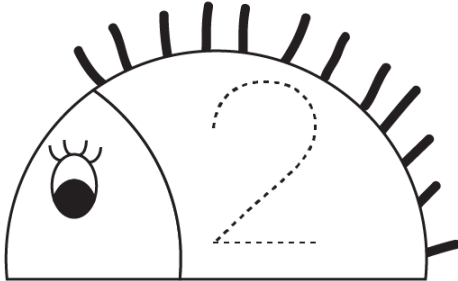
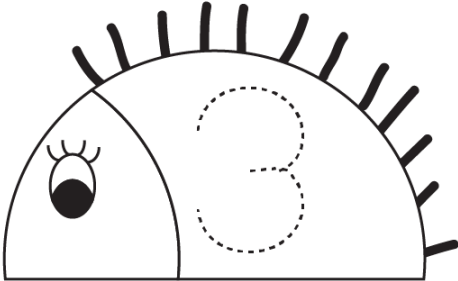
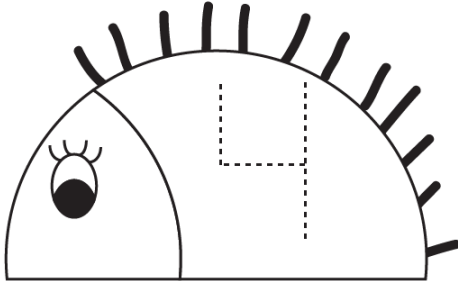
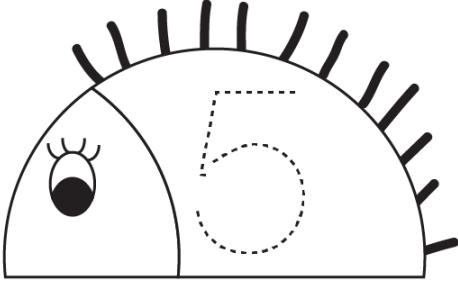
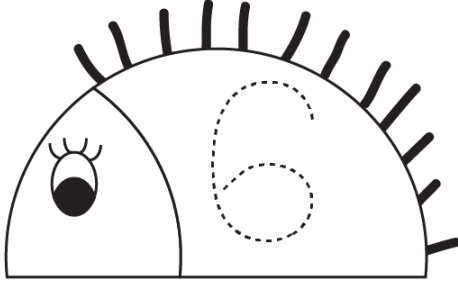
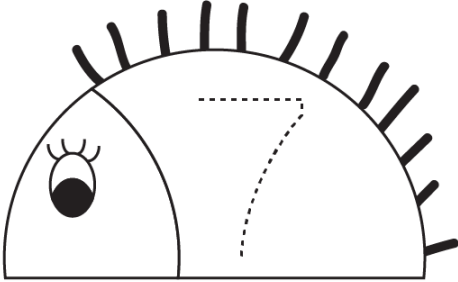
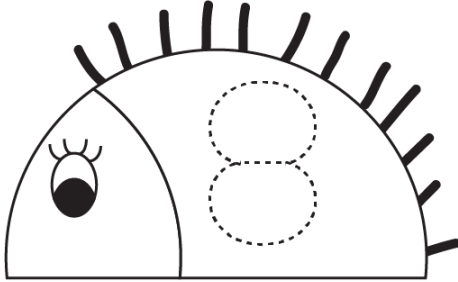
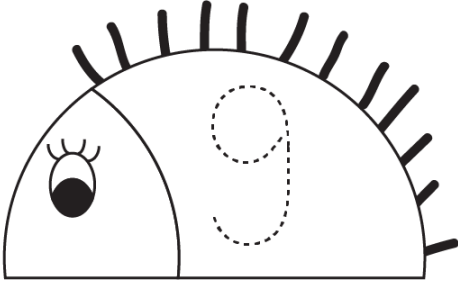
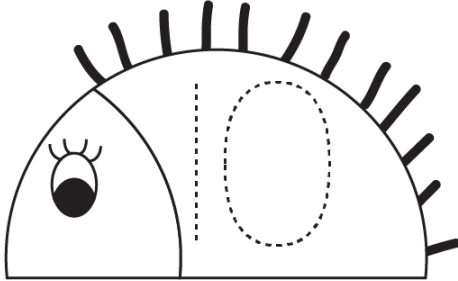



Grade 1 Warm up

Student's Name

Match the shapes.

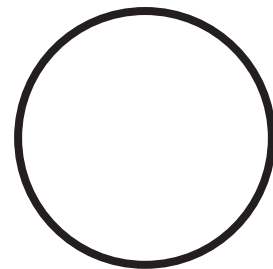
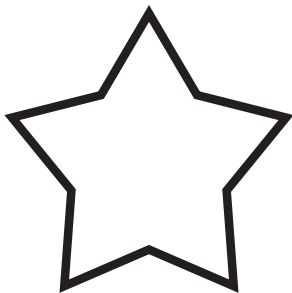
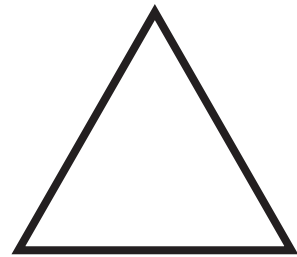
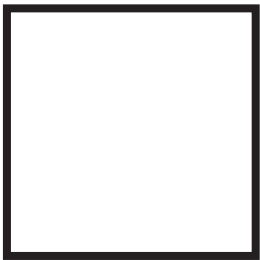
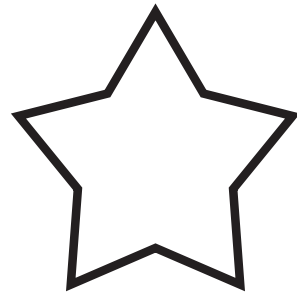
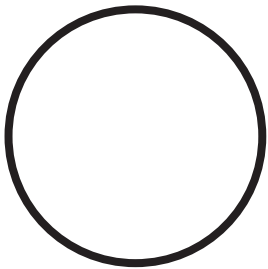
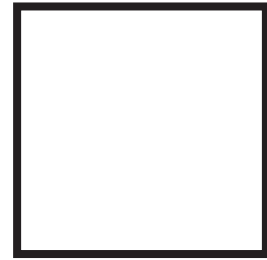
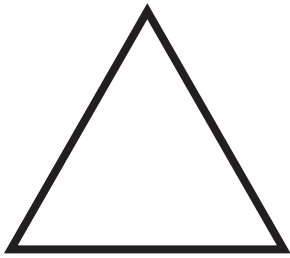



Grade 1 Warm up

Student's Name

Draw the faces.

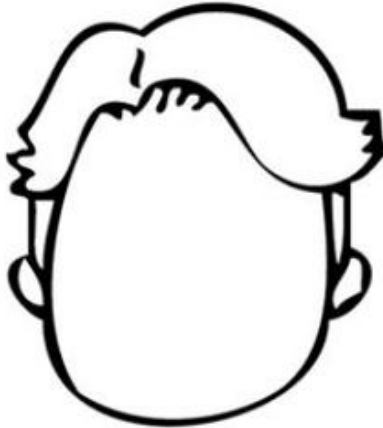

I'm happy



I'm sad



I'm sleepy



I'm afraid



I'm angry



I'm hot



Gradel Warm up

Student's Name

Cut on the dotted line until you reach the bug.

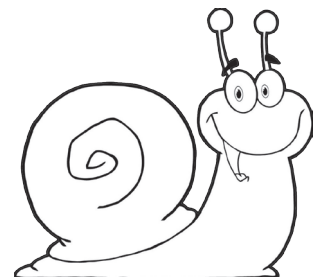
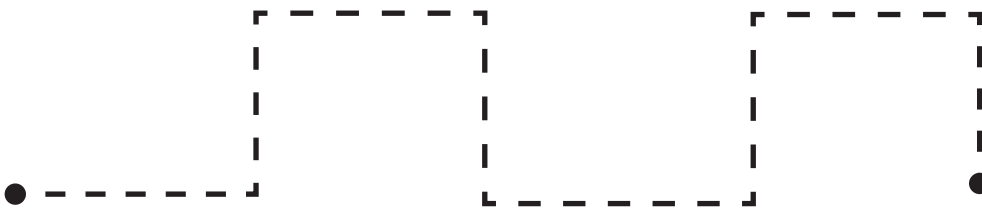
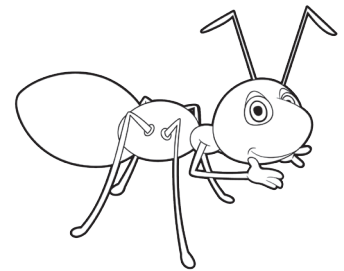
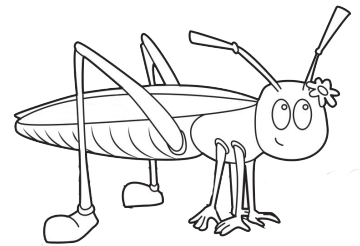
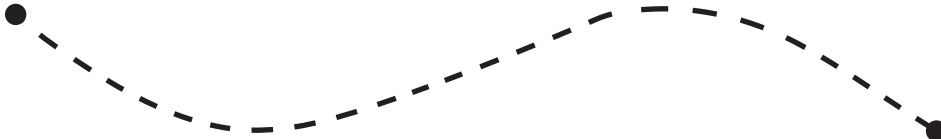



Grade 1 Warm up

Student's Name

Trace the lines from the airplane to the pilot.

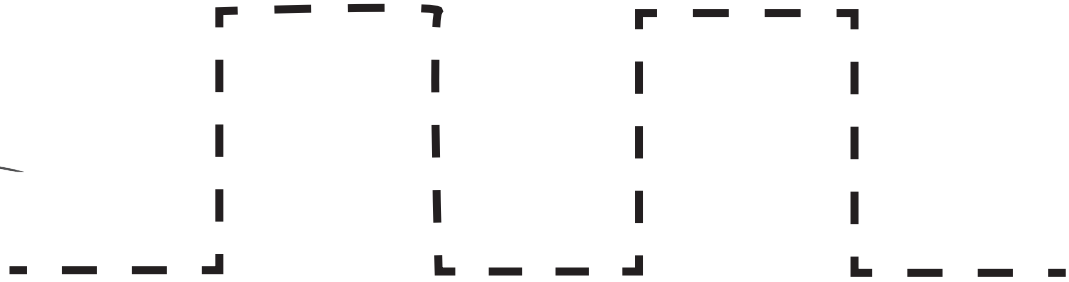



Grade 1 Warm up

Student's Name

Past the parts to make the picture.

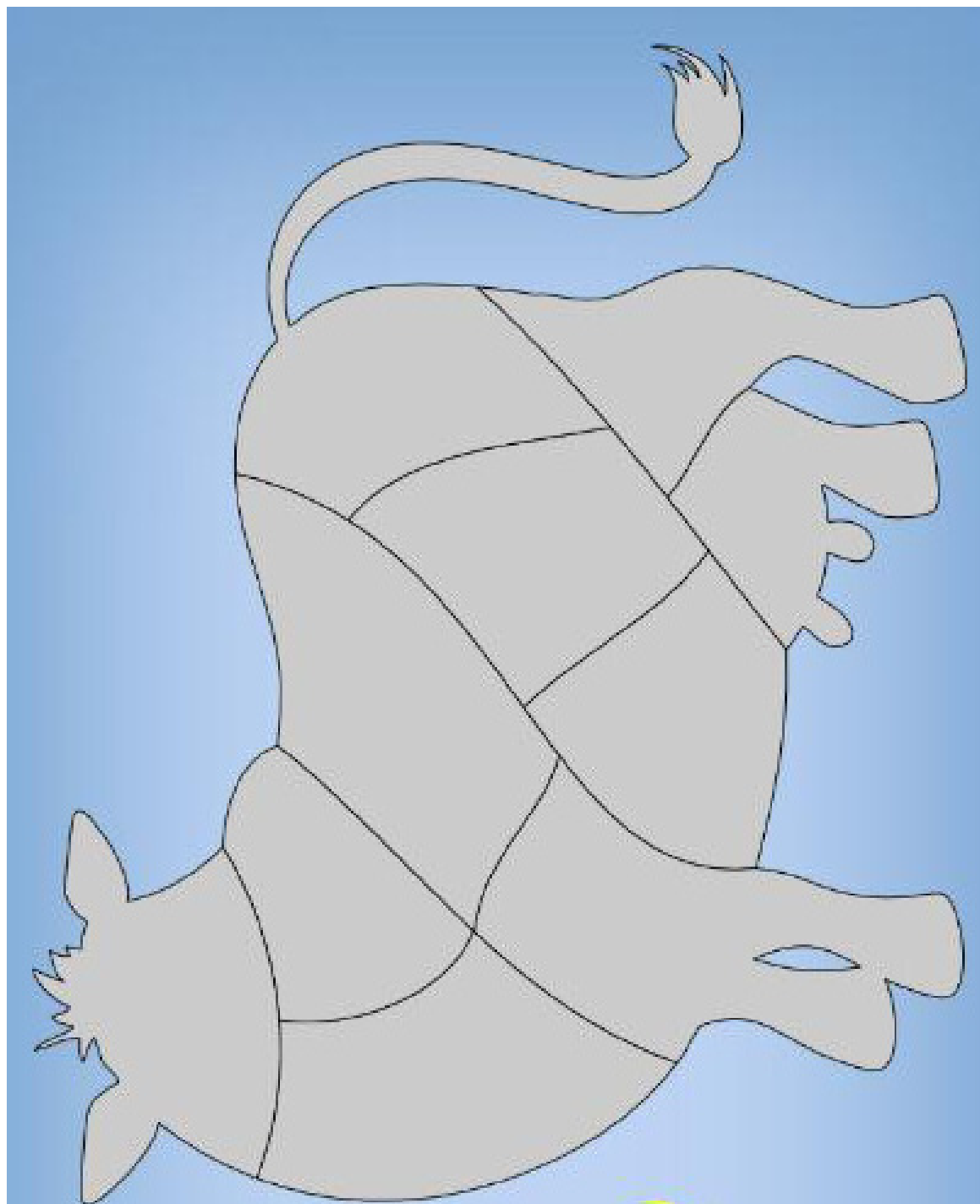





Grade 1 Warm up

Student's Name

Trace and color the ovals.

The illustration shows three cartoon eggs with faces, eyes, and mouths, standing on a small patch of ground. The egg on the left has a surprised expression with wide eyes and an open mouth. The middle egg has a neutral expression. The egg on the right has a slightly grumpy or thoughtful expression with a small frown. Below the illustration are seven dashed ovals of various sizes and orientations, intended for tracing practice.



Grade 1 Warm up

Student's Name

Go from start to end.

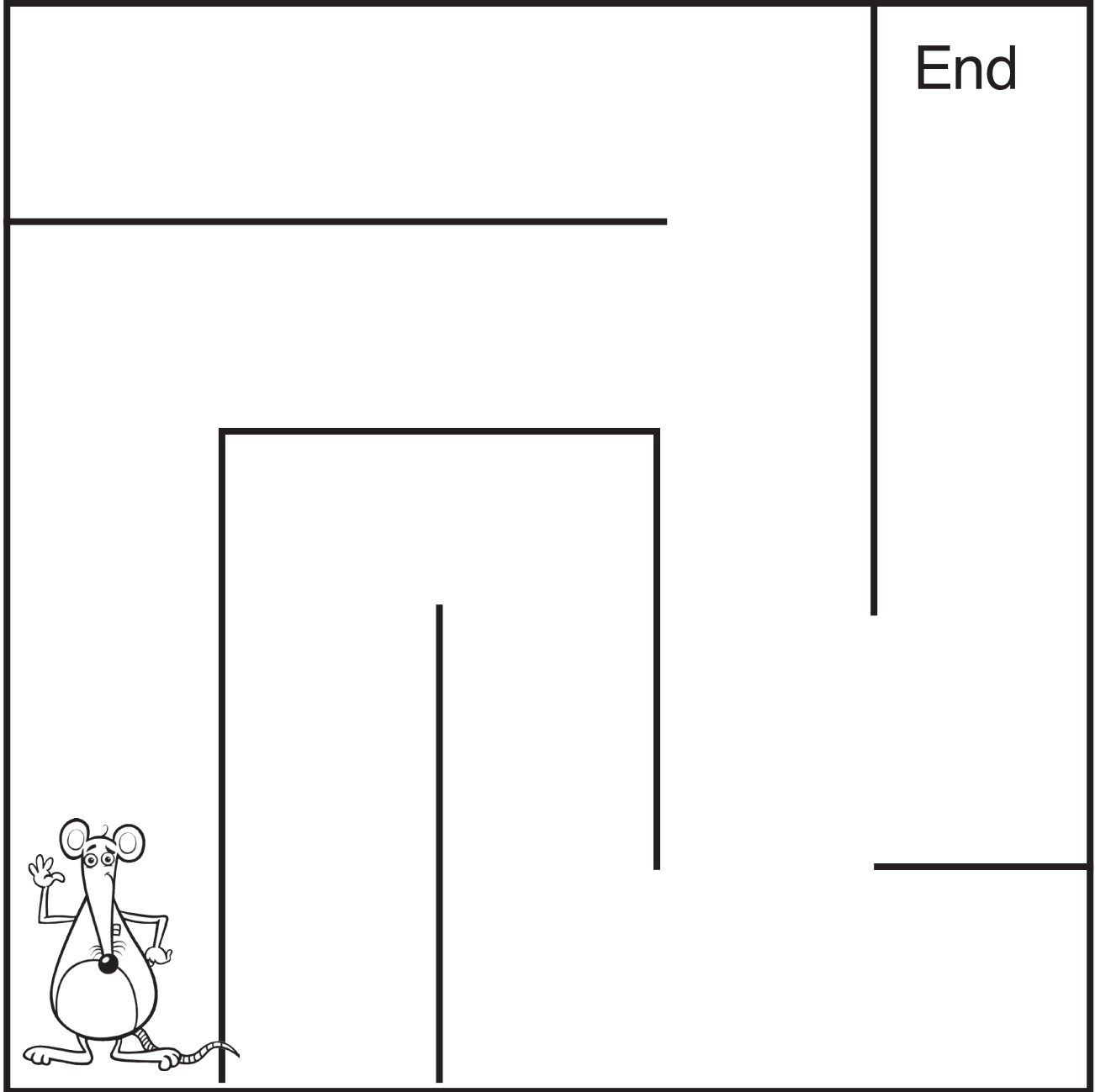

Start



Gradel Warm up

Student's Name

Trace the diagonal lines. Then use scissors to cut -the lines.

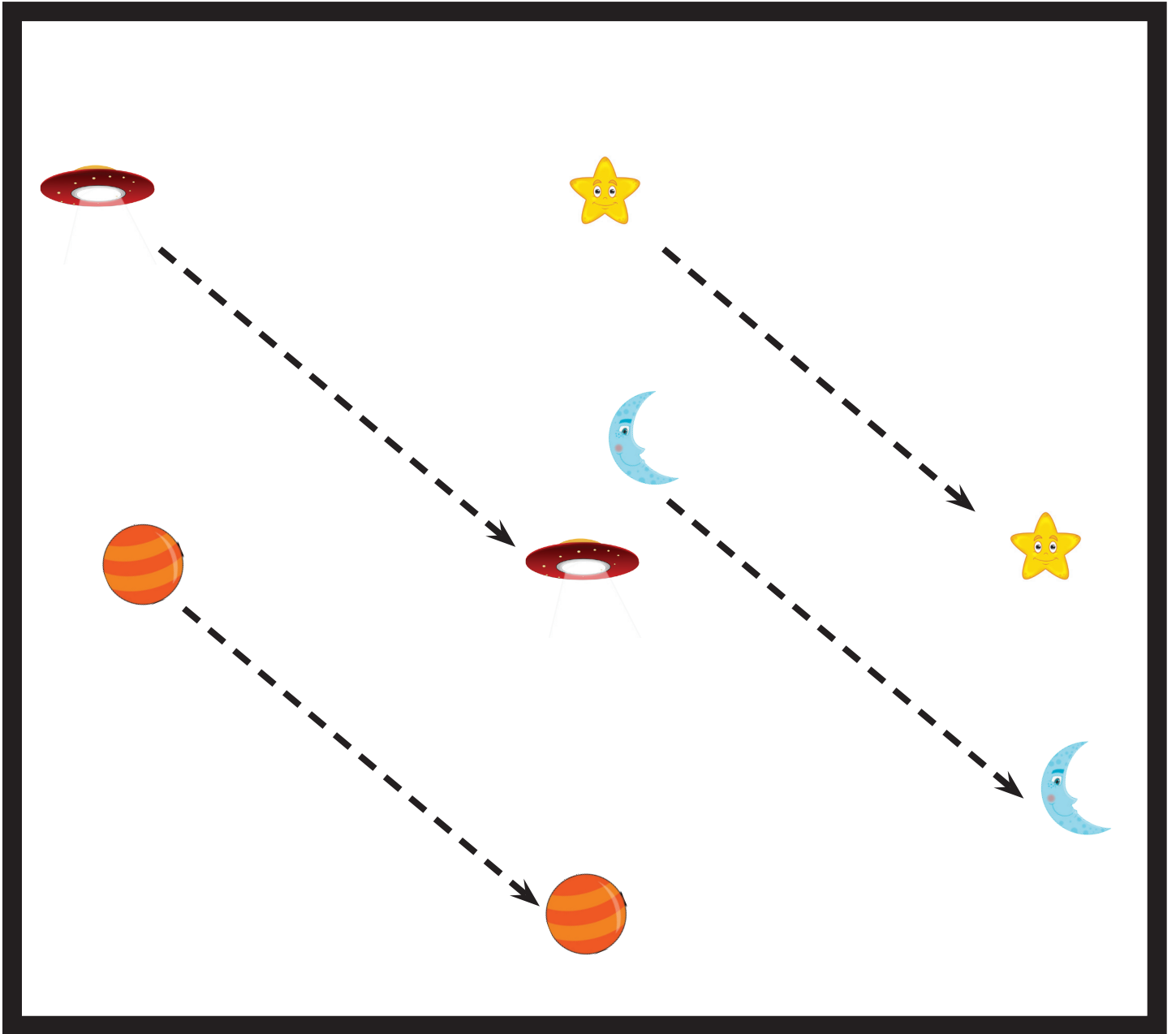



Gradel Warm up

Student's Name

Complete the photo.

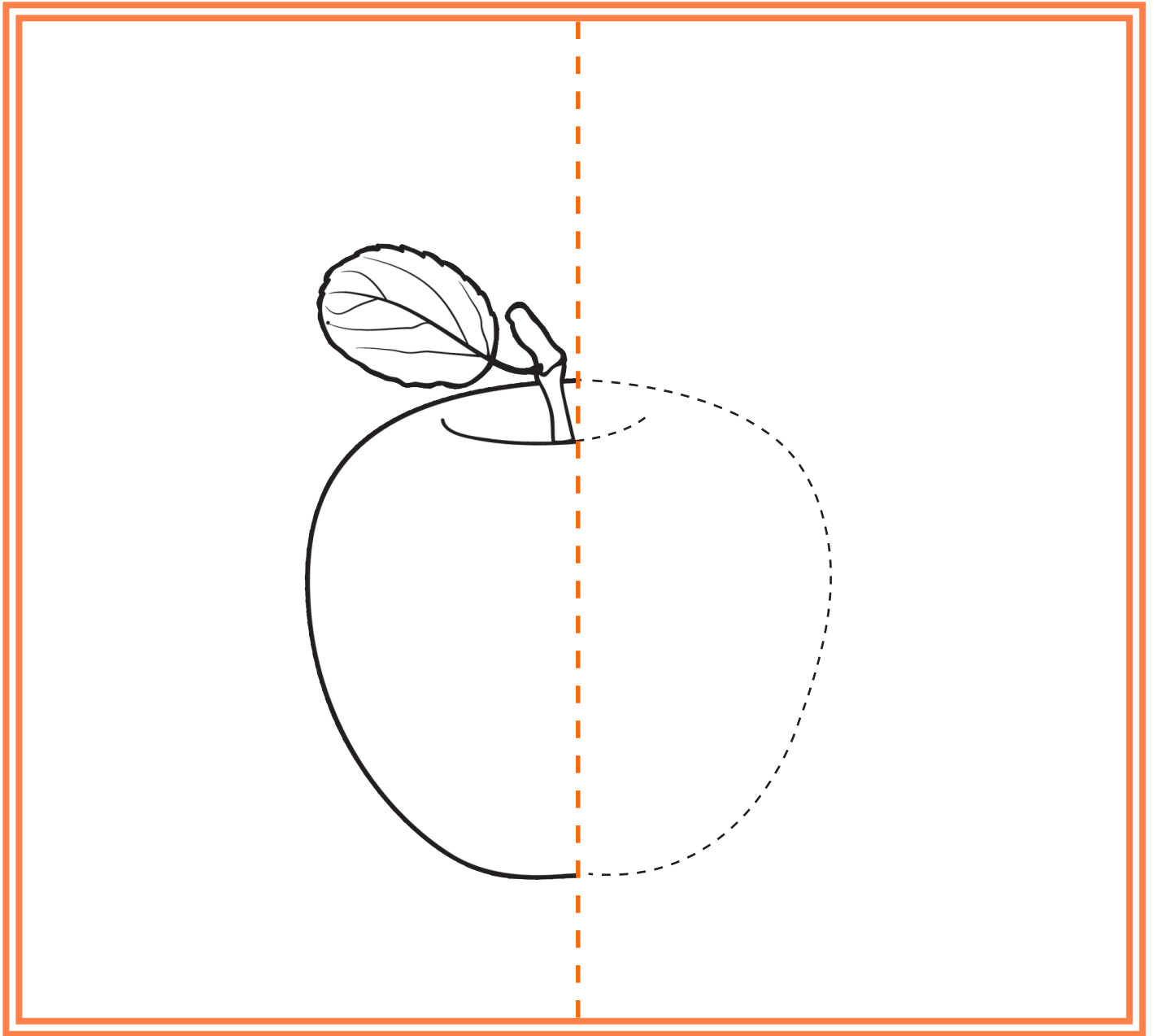



Gradel Warm up

Student's Name

Complete the photo.

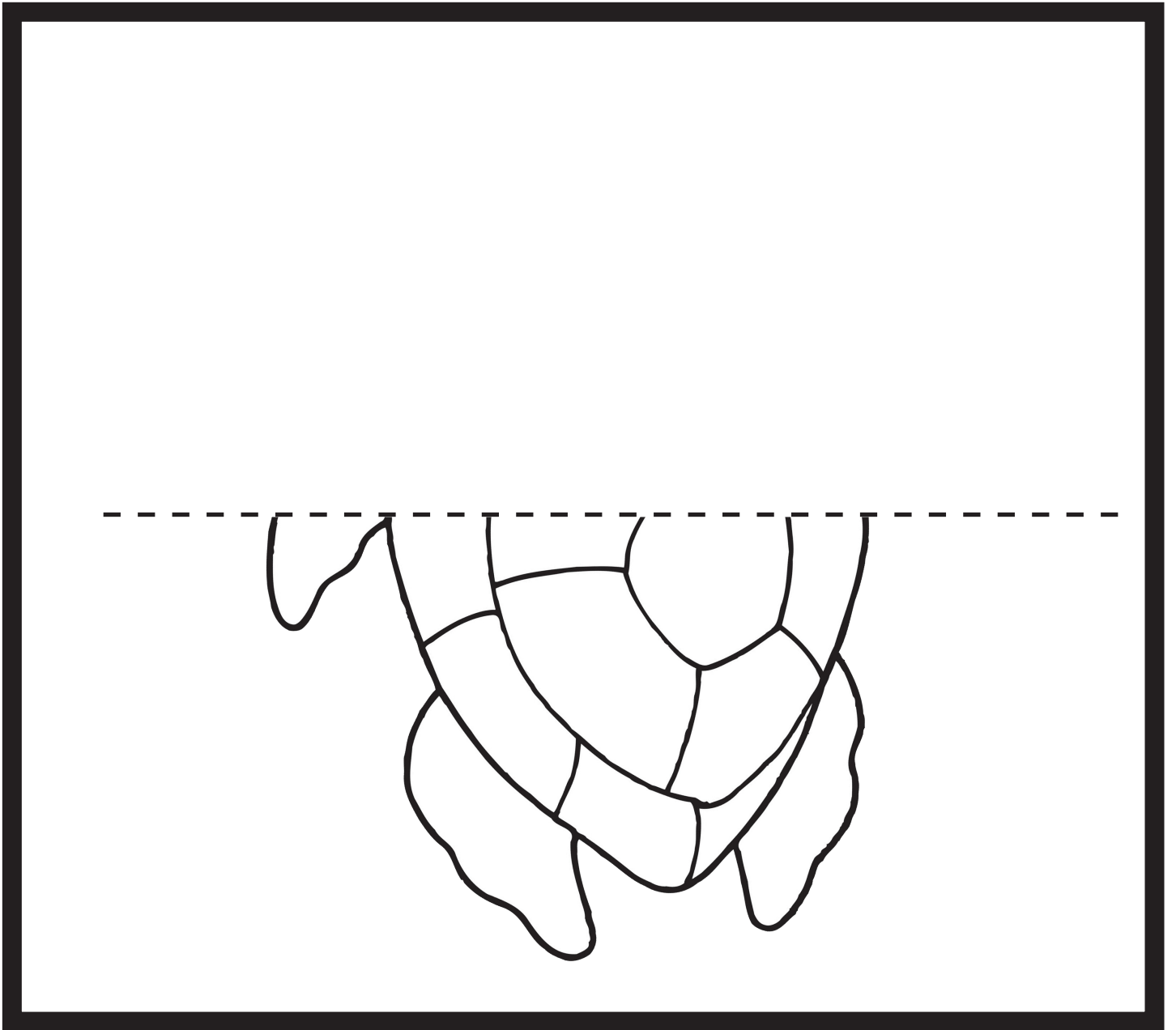



Gradel Warm up

Student's Name

Colour.





Gradel Warm up

Student's Name

Draw a line to match the parents to their babies.

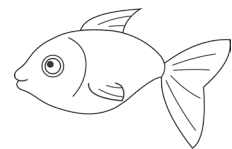
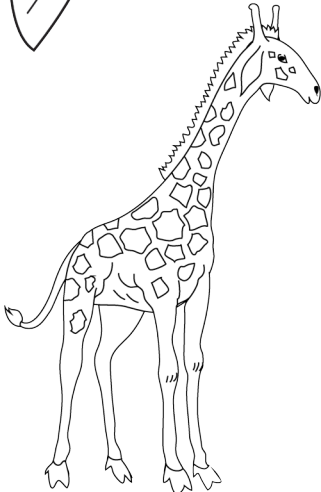
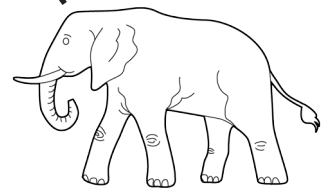
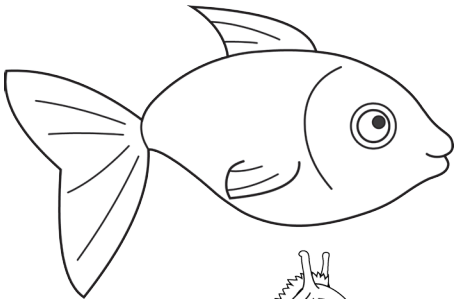
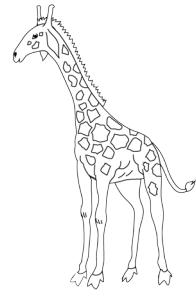
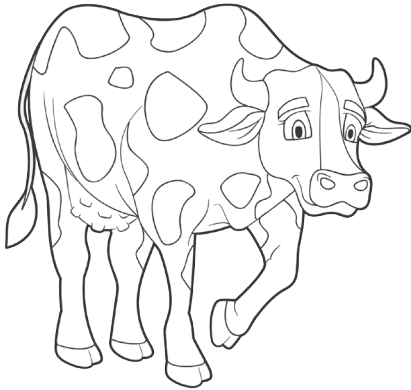
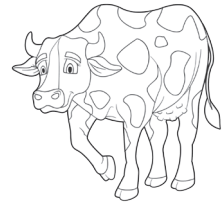
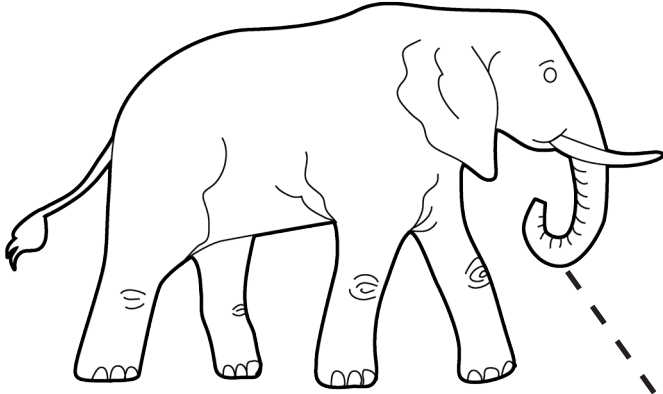



Grade 1 Warm up

Student's Name

Connect the dots.

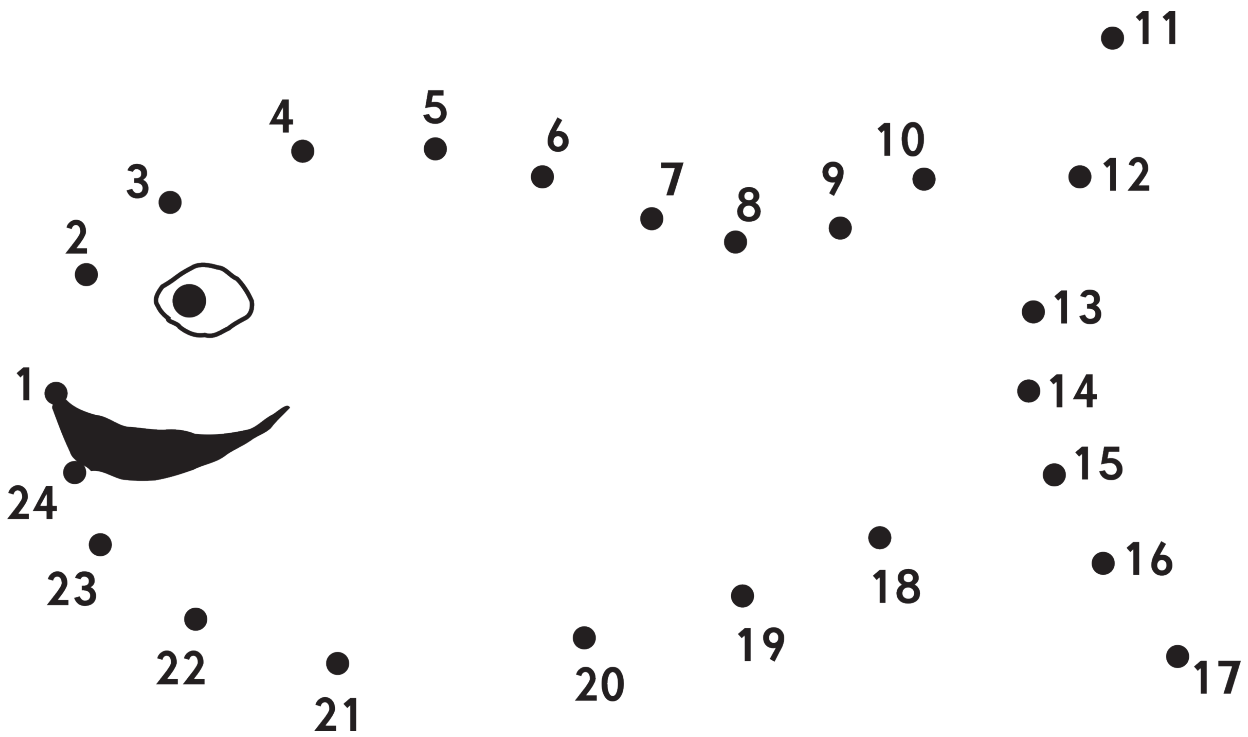



Gradel Warm up

Student's Name

Help the kid take his bag.

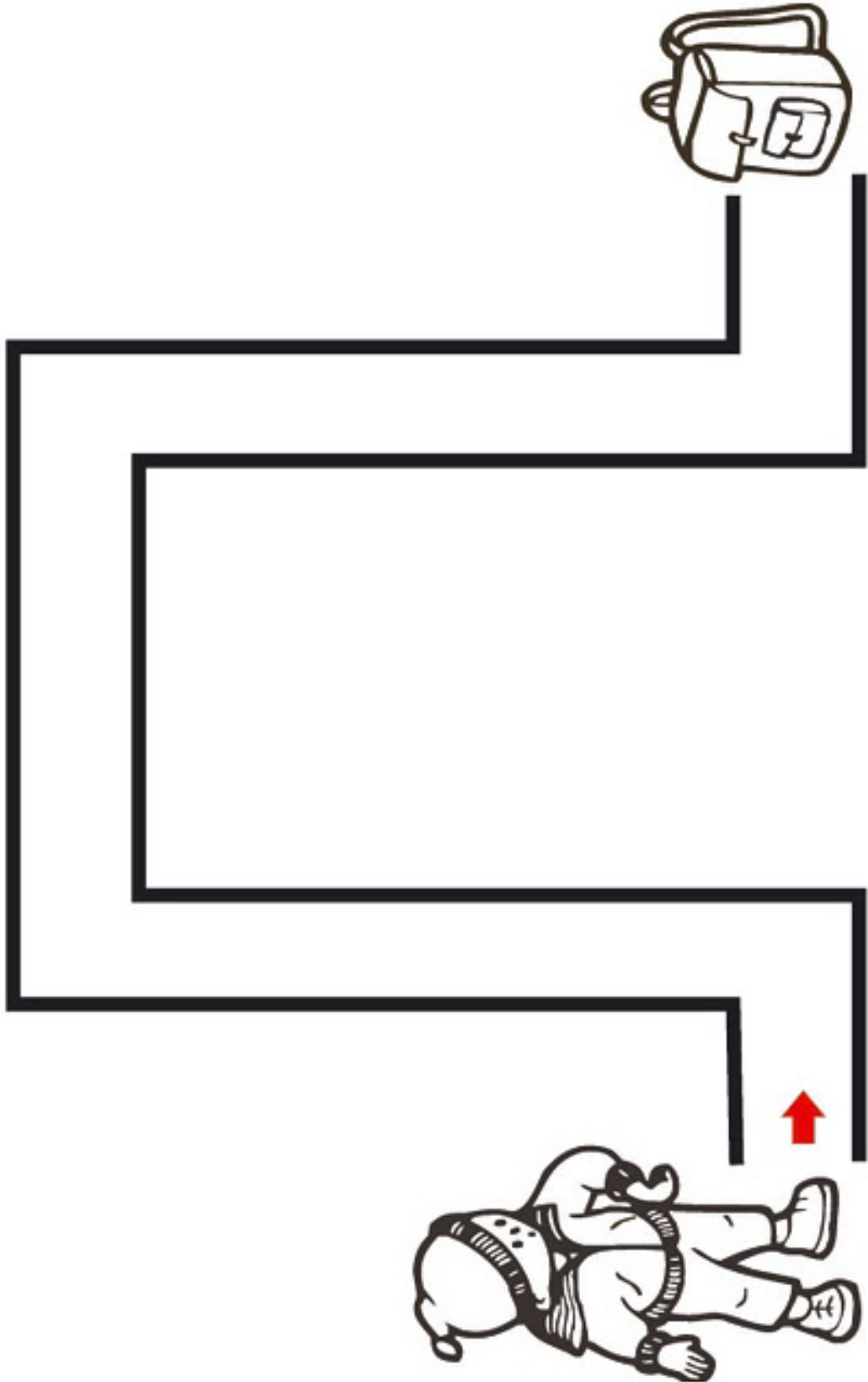



Grade 1 Warm up

Student's Name

Colour, trace and connect.

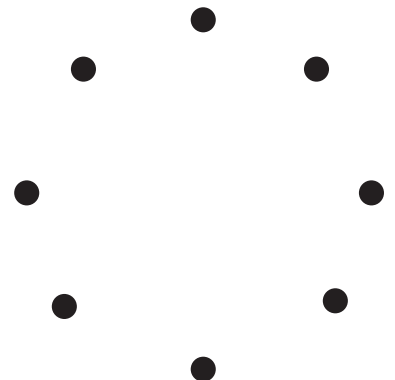
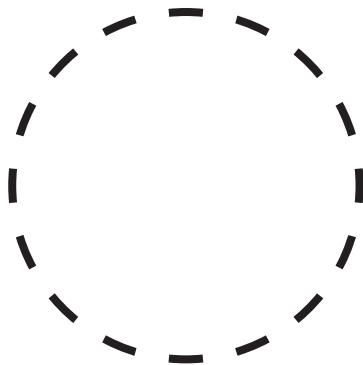
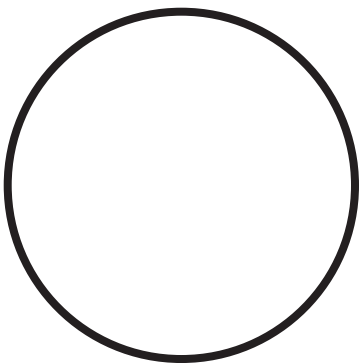
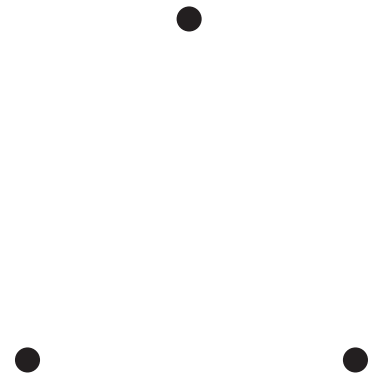
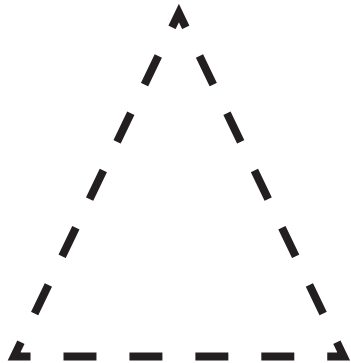
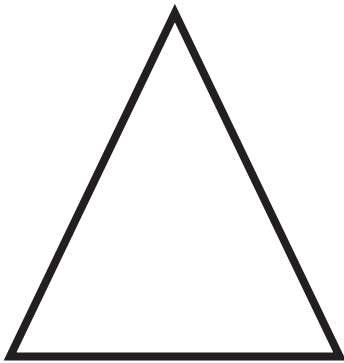
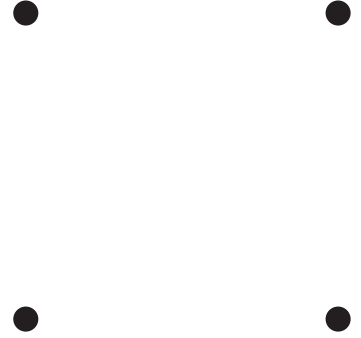
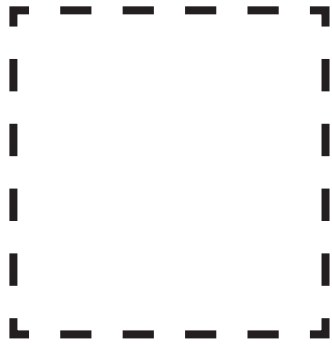
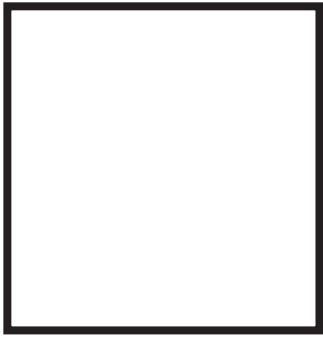







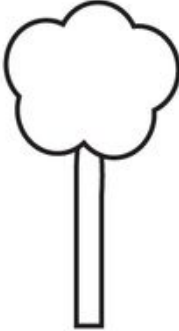
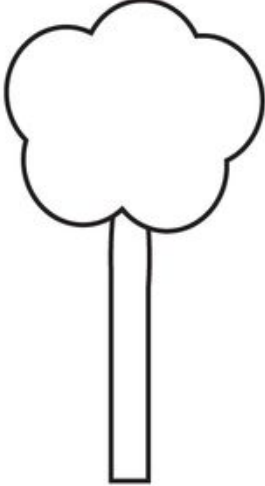

Gradel Warm up

Student's Name

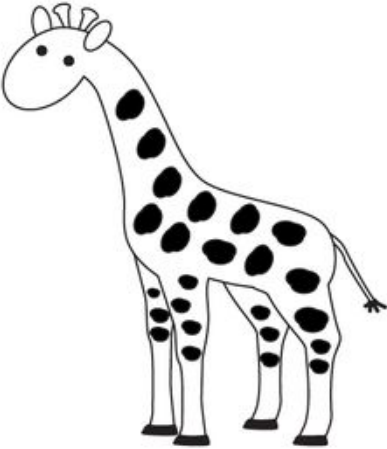
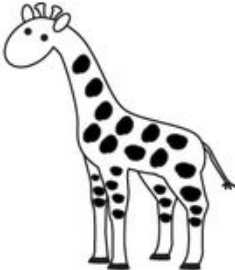
Circle the tallest one.

		
		
		



Grade 1 Warm up

Student's Name

Help Buzzy reach his friends!

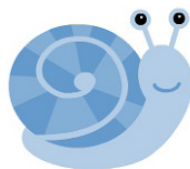
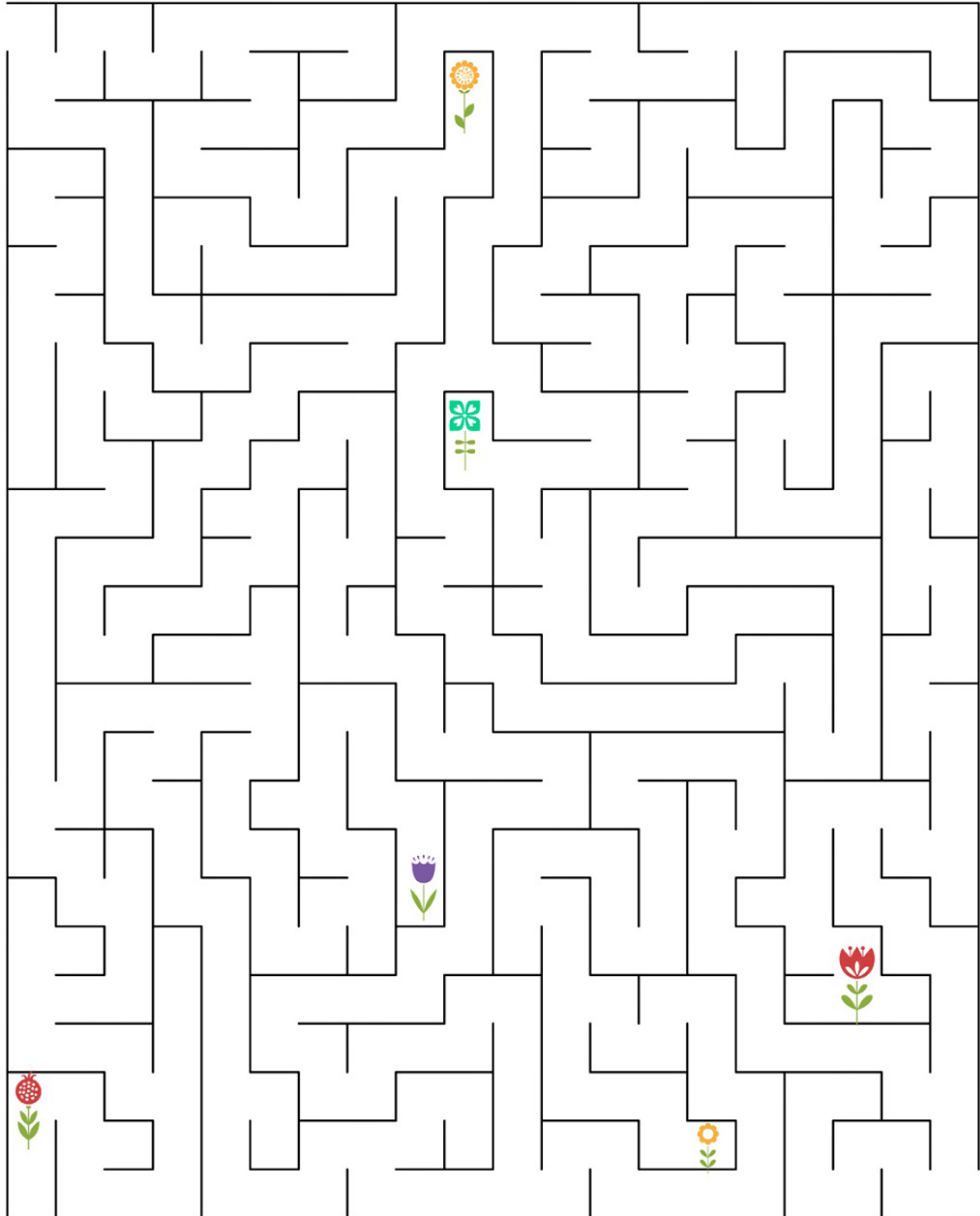



Grade 1 Warm up

Student's Name

Help the car go home.

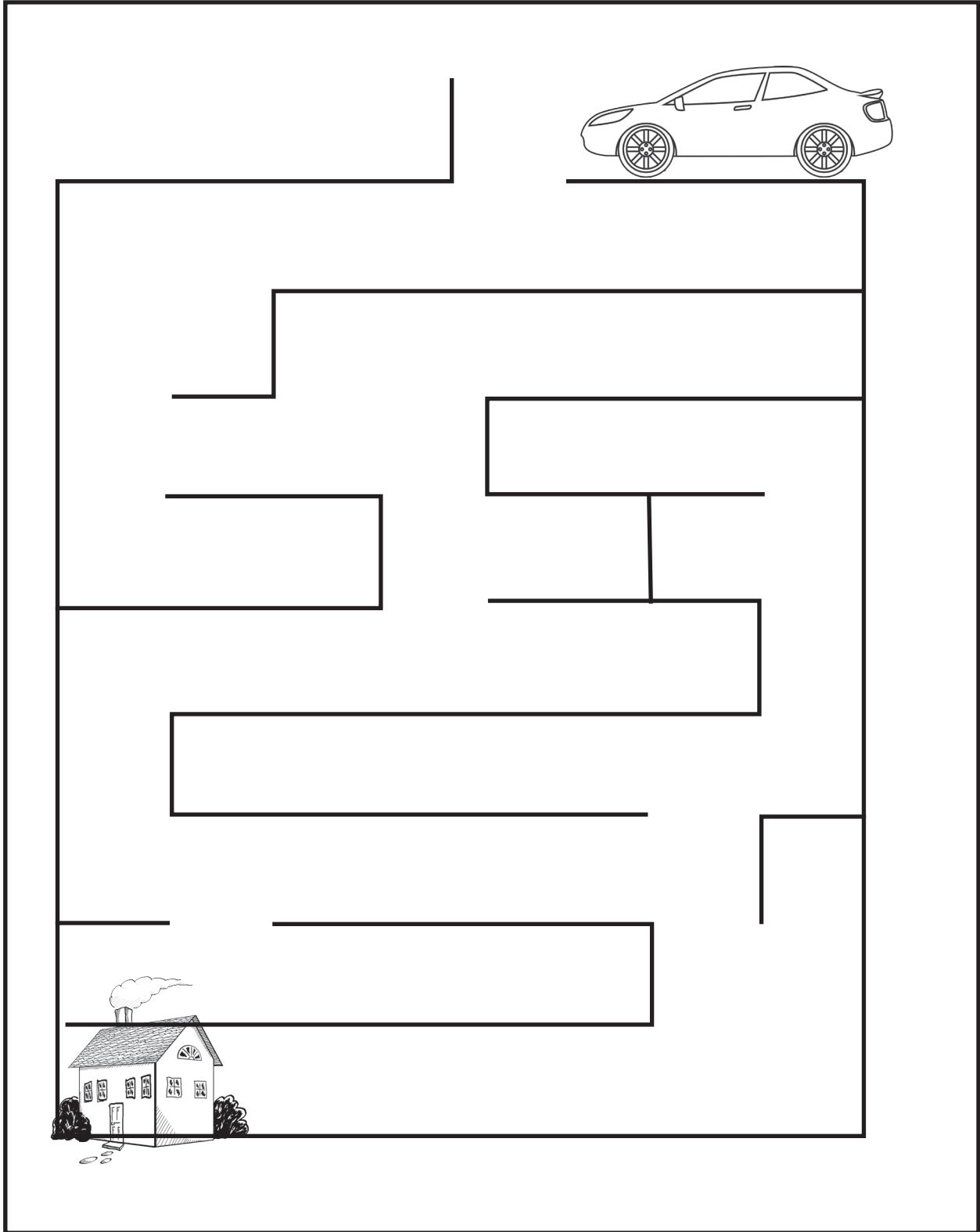



Gradel Warm up

Student's Name

Complete the photo.

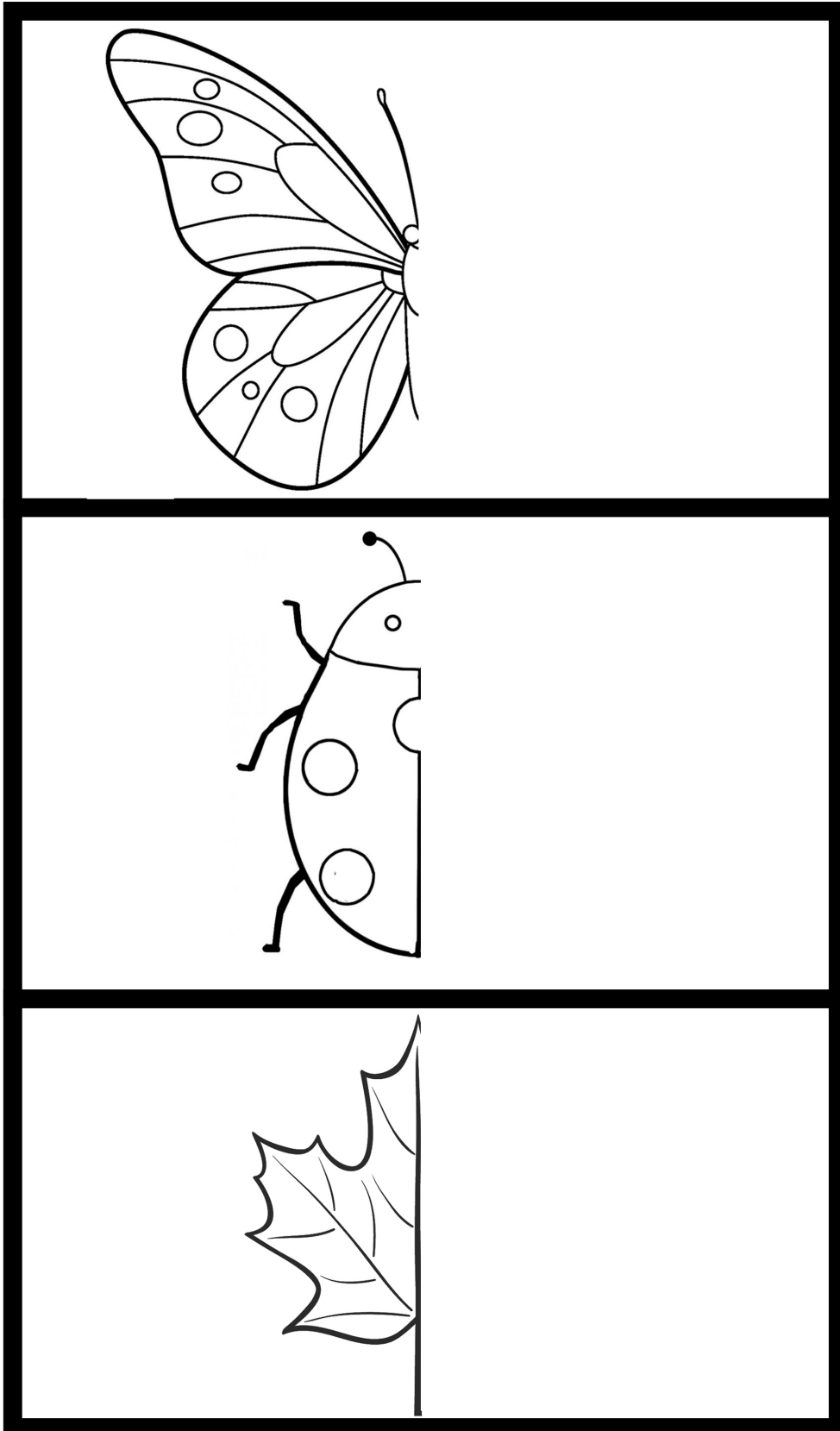



Gradel Warm up

Student's Name

Cut the star and colour it.

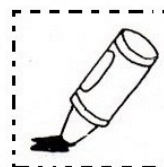
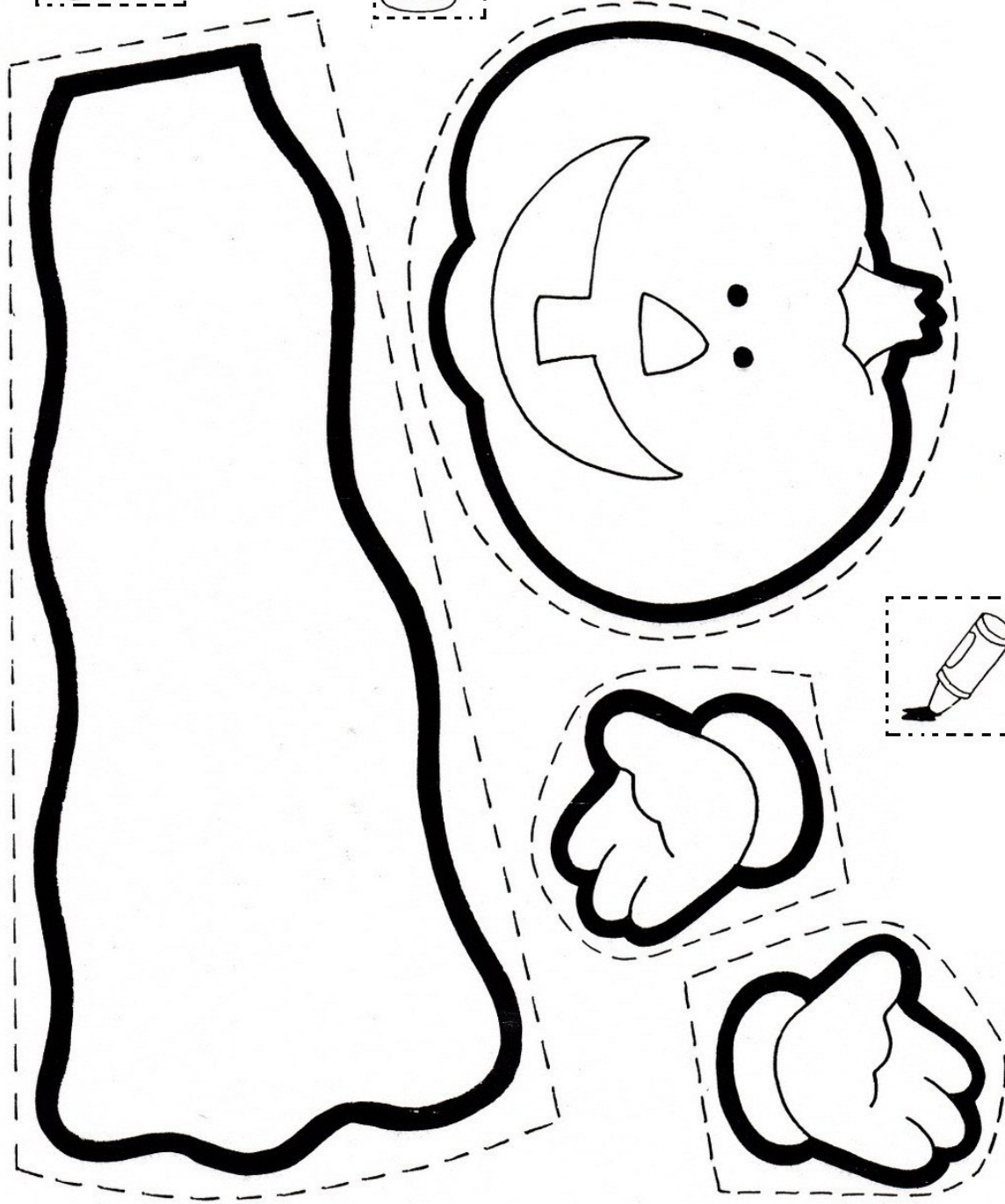
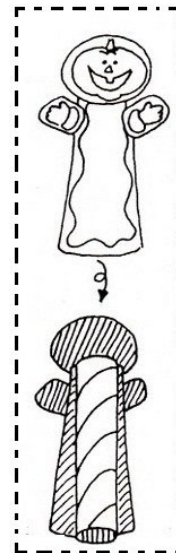



Grade 1 Warm up

Student's Name

Colour the photo.

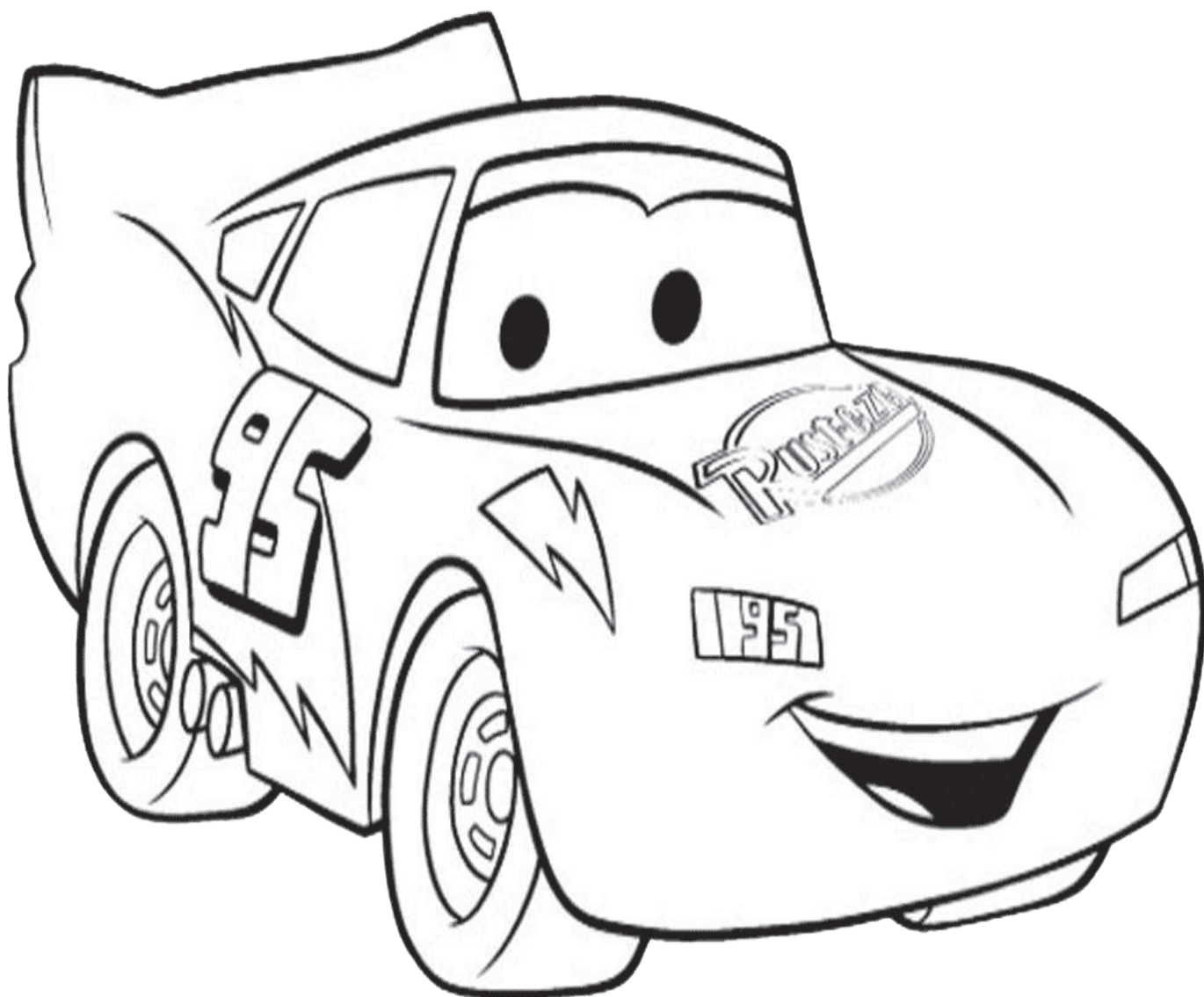



Grade 1 Warm up

Student's Name

Trace and match.

sad



scared



happy



surprised



mad





Grade 1 Warm up

Student's Name

Write the number before.

, 3

, 6

, 2

, 9

, 4

, 8

, 10

, 5

, 8

, 10

, 5

, 1

, 3

, 7

, 6

, 3



Grade 1 Warm up

Student's Name

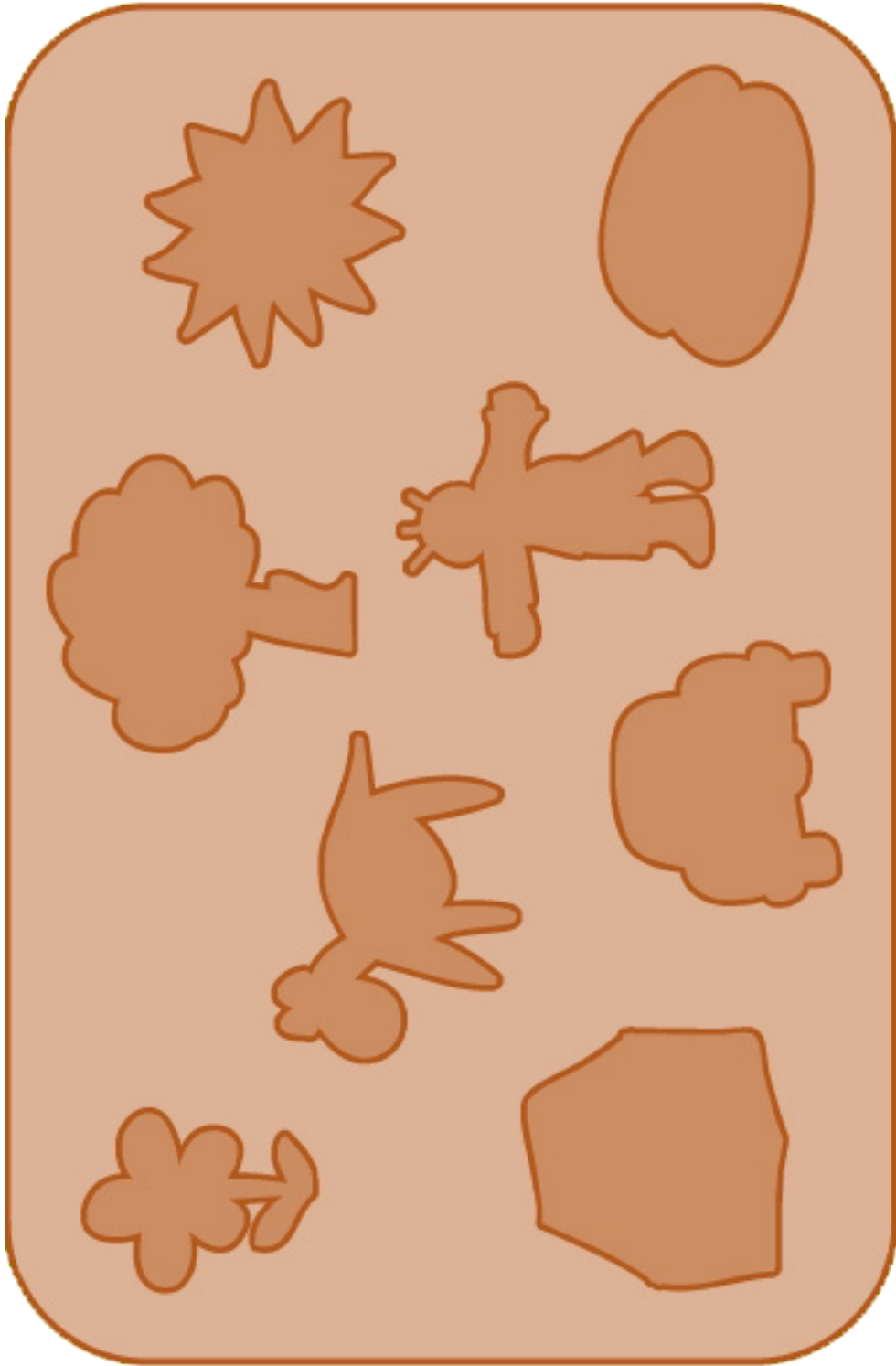









Grade 1 Warm up

Student's Name

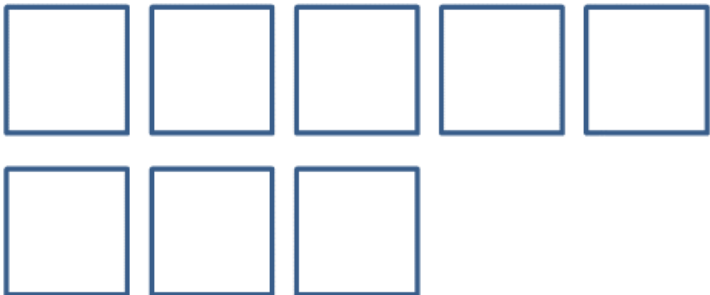
Draw lines to connect the numbers and shapes that go together.

3
4
5
6
7
8



Grade 1 Warm up

Student's Name

Cut and collect.











Grade 1 Warm up

Student's Name

Help the rocket get to Saturn.

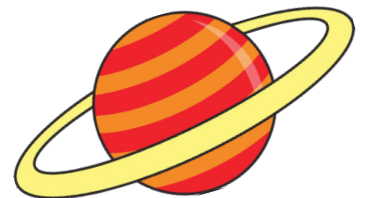
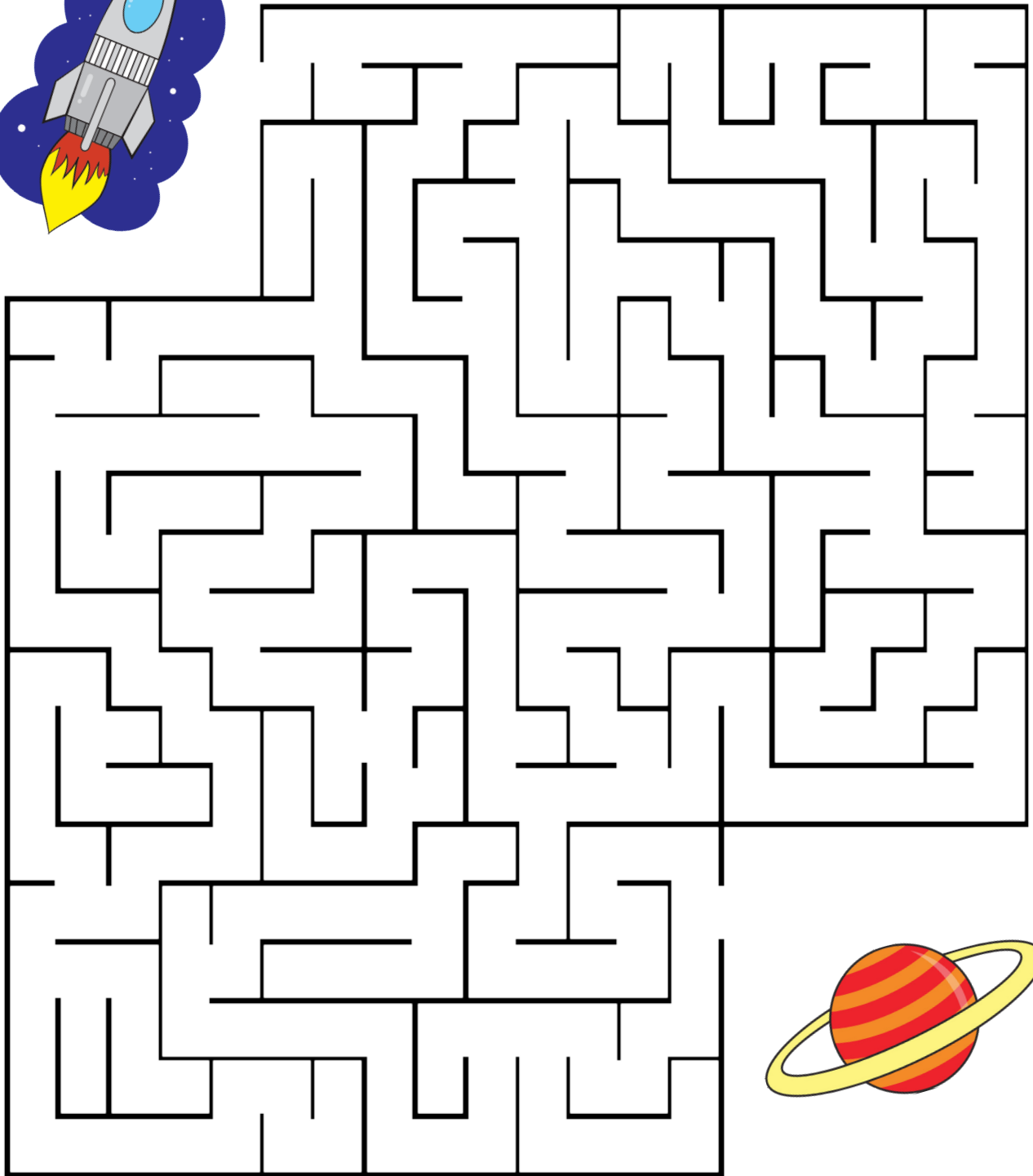
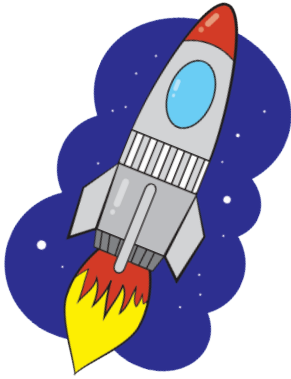



Grade 1 Warm up

Student's Name

Can you make it to bed?

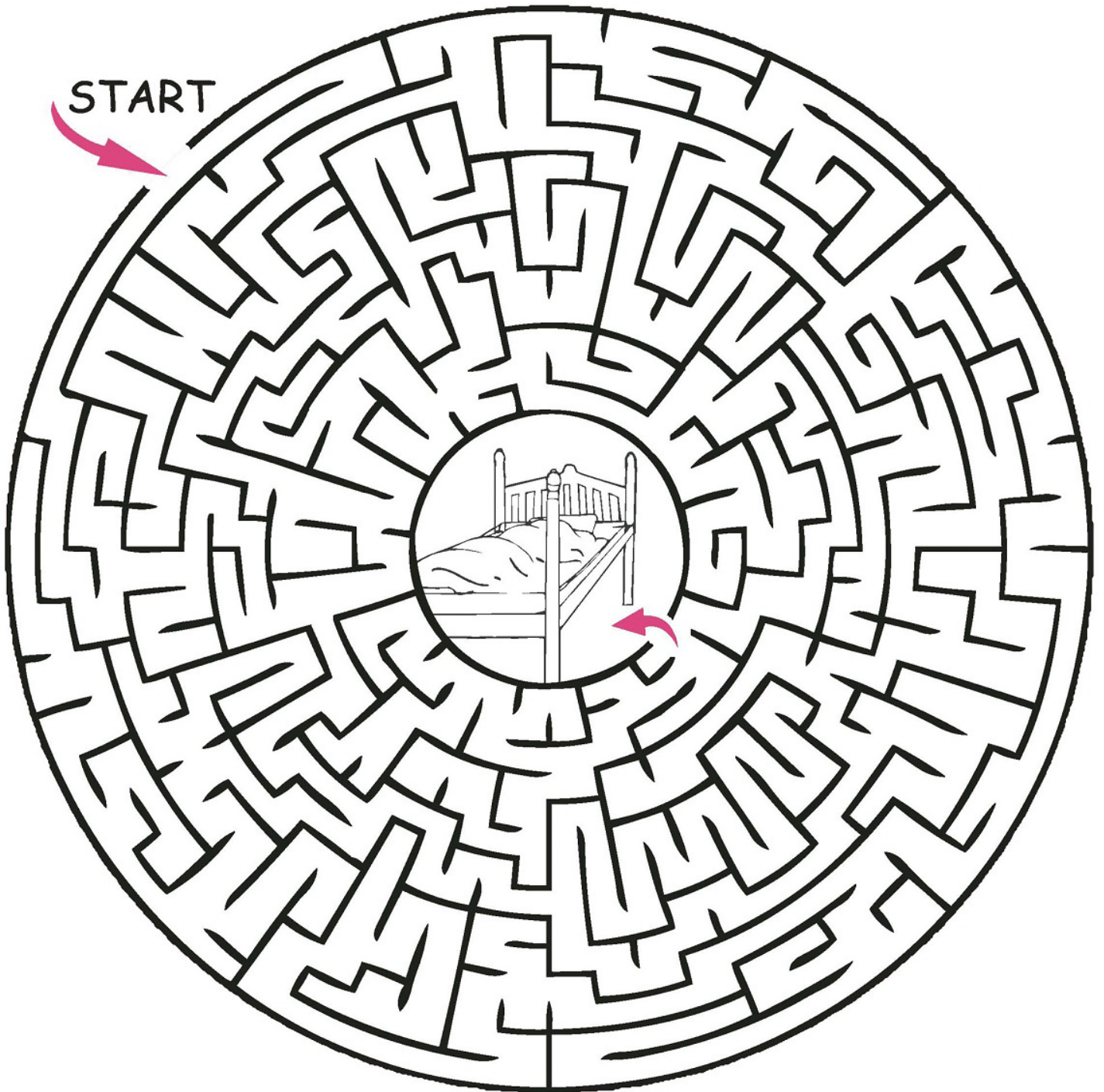



Grade 1 Warm up

Student's Name

Match the pictures with words.

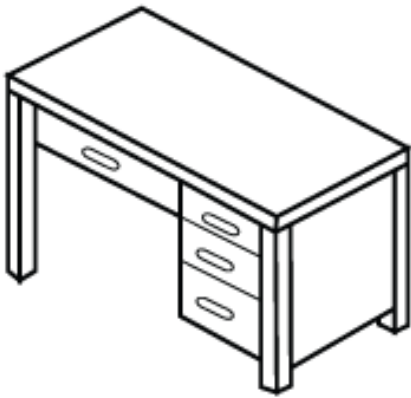

ball

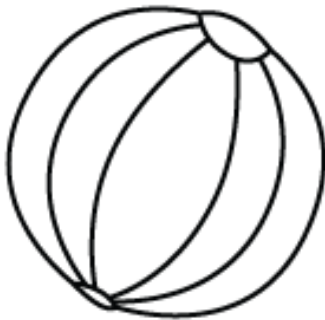

bed

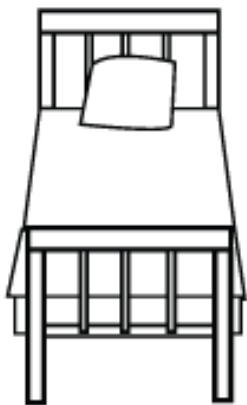

desk



Grade 1 Warm up

Student's Name

Cut and paste

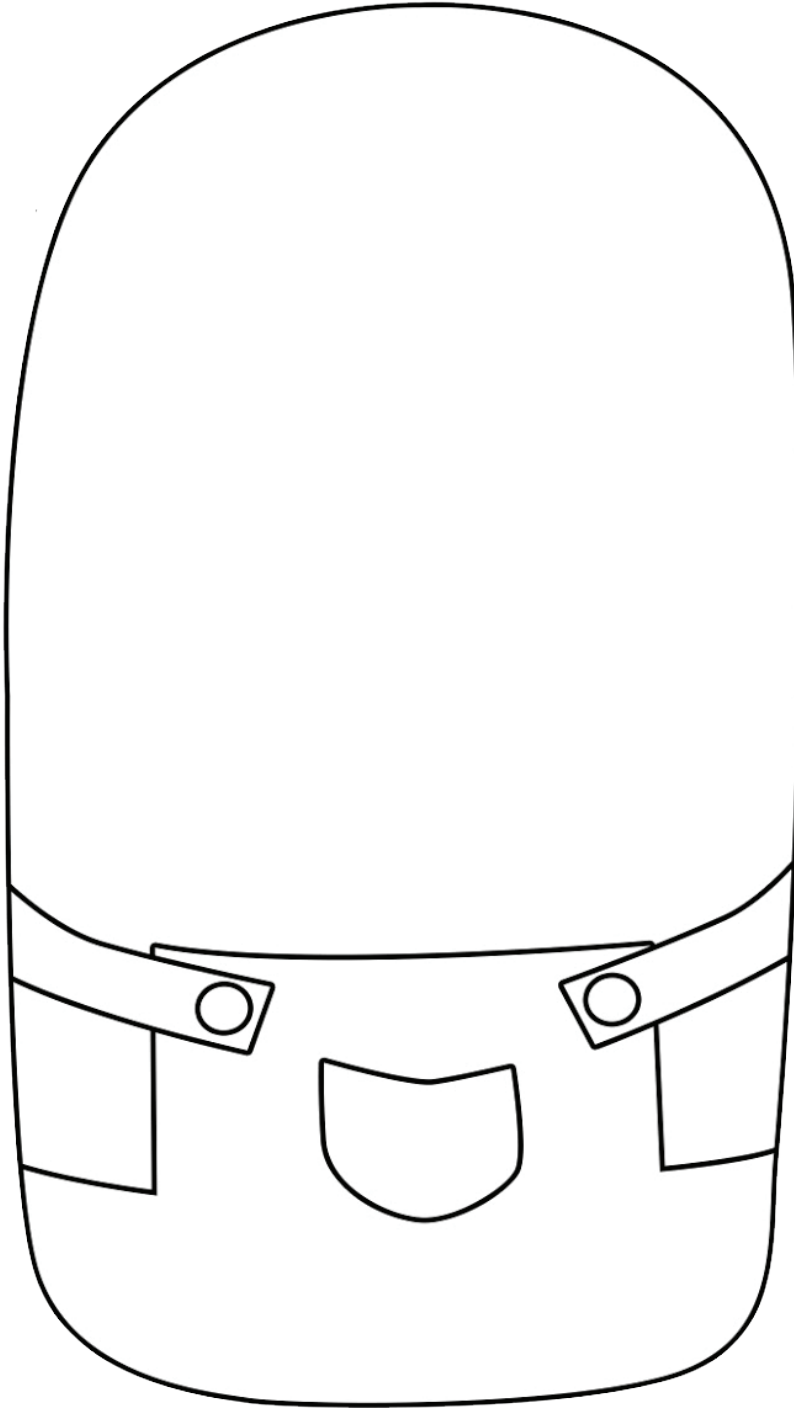

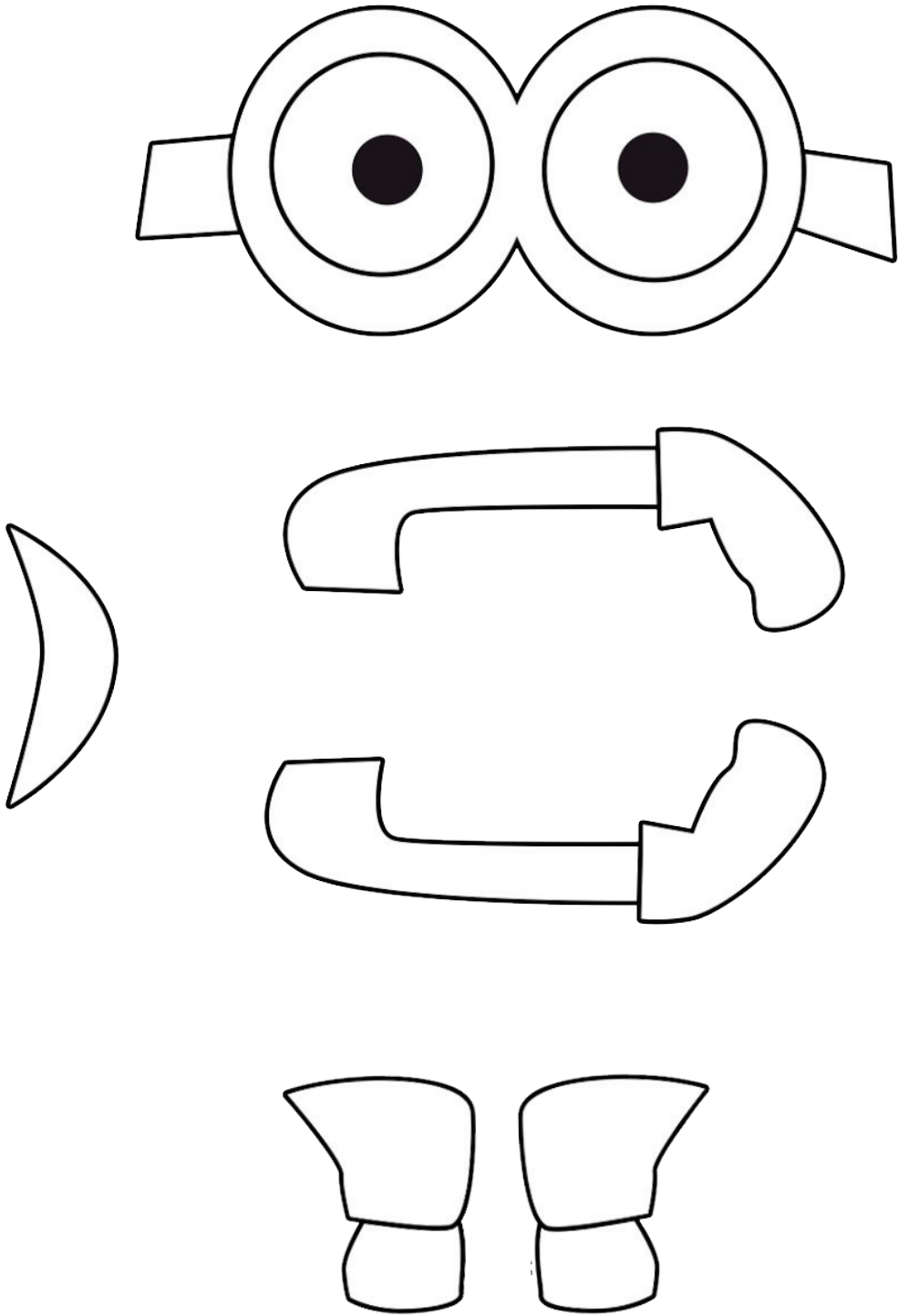



Gradel Warm up

Student's Name

Cut and paste

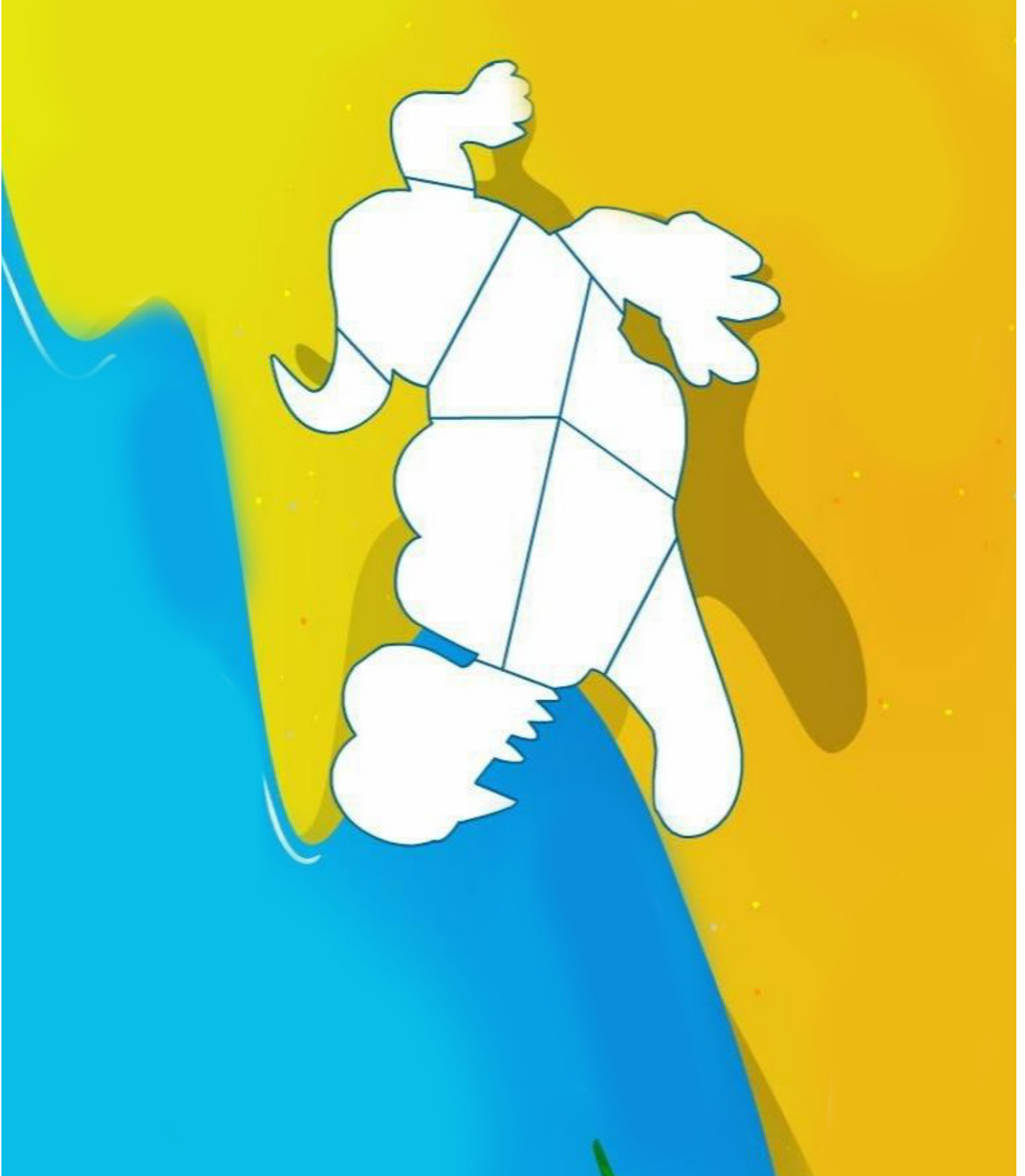



Grade 1 Warm up

Student's Name





Grade 1 Warm up

Student's Name

Cut and paste







Grade 1 Warm up

Student's Name

Colour the different shapes.

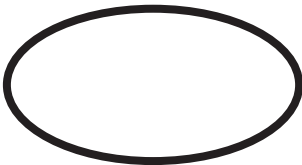
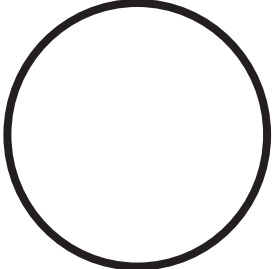
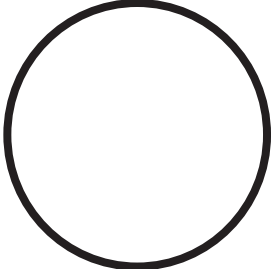
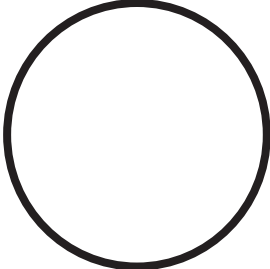
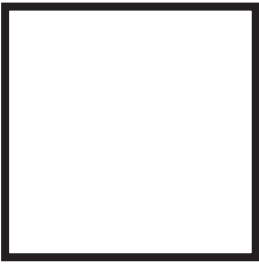
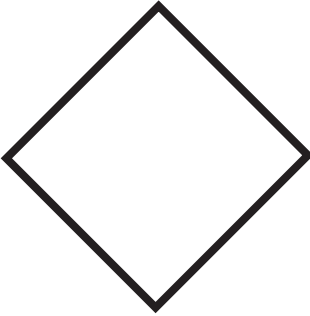
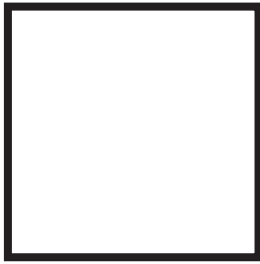
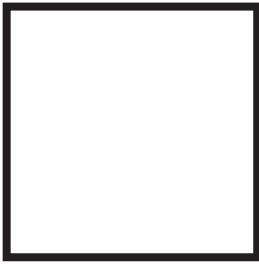
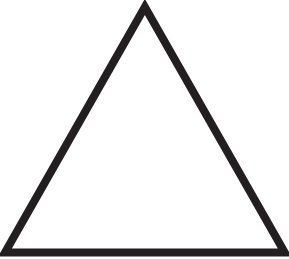
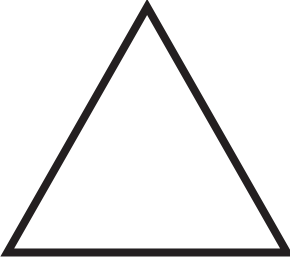
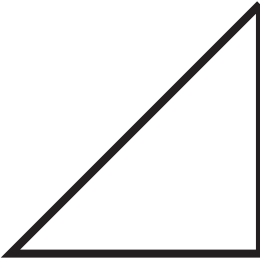
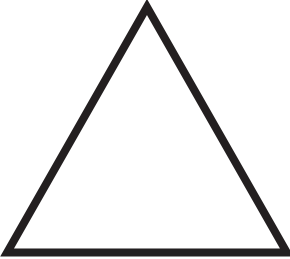
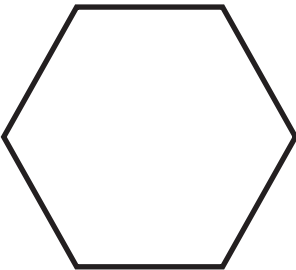
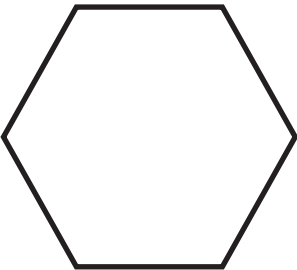
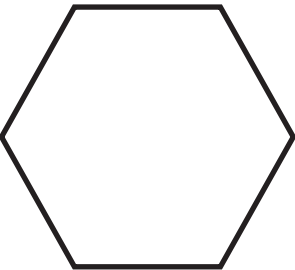
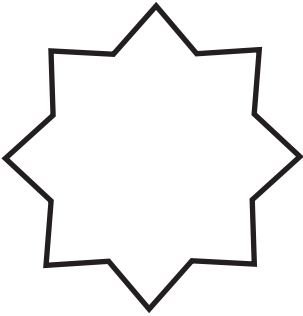

1 Trace and write.

Good afternoon

Good afternoon

Good morning

Good morning

Good night

Good night

Good evening

Good evening



2 Draw (sun, moon or stars in each window).

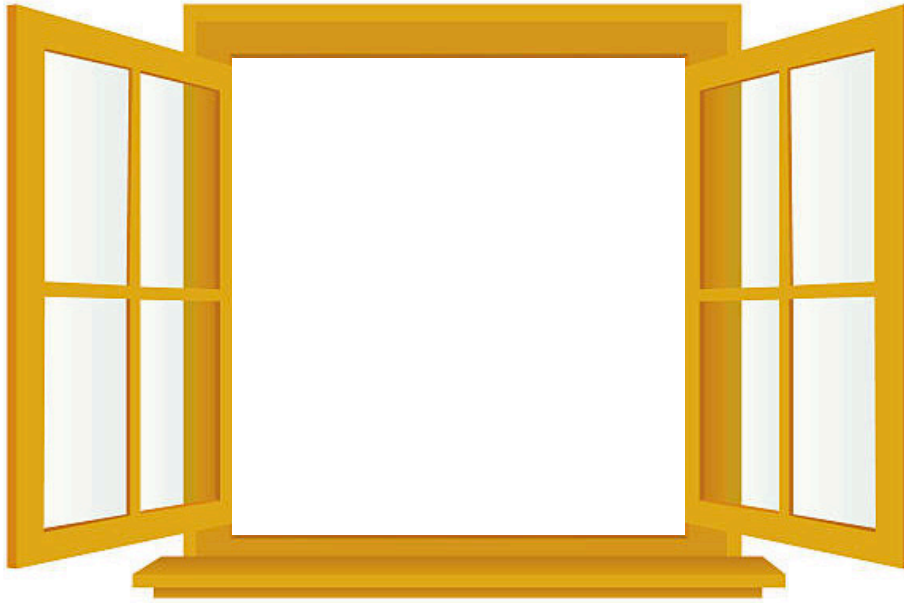

Good evening

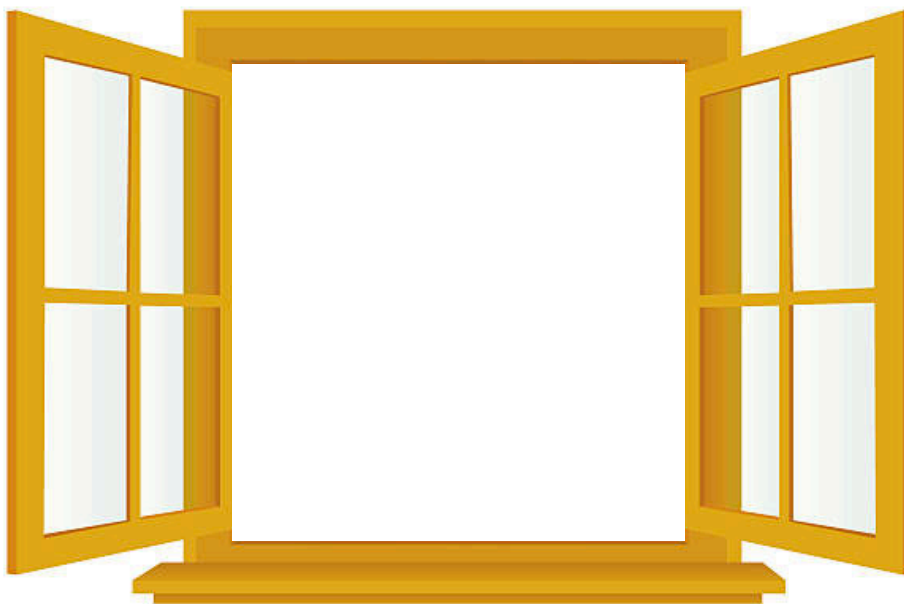

Good morning

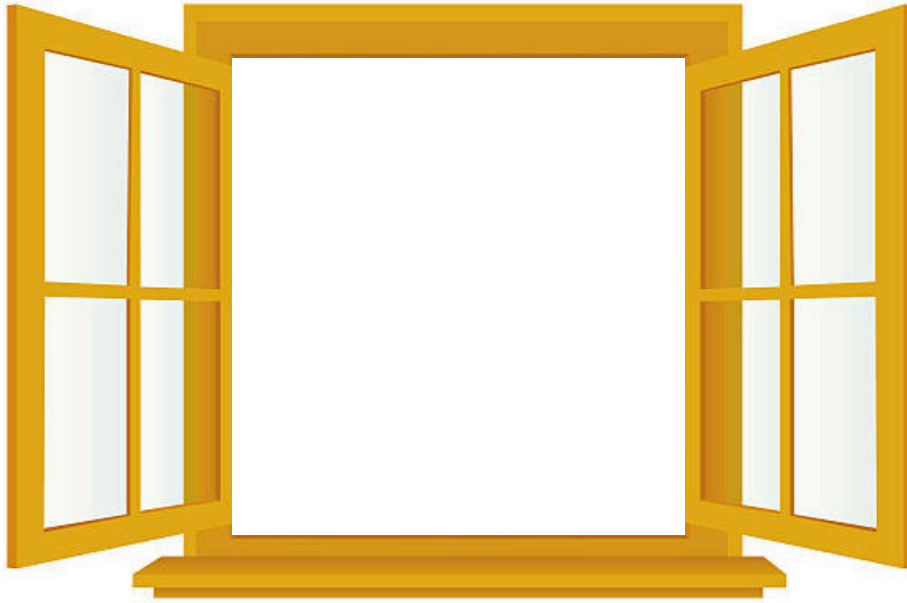

Good night

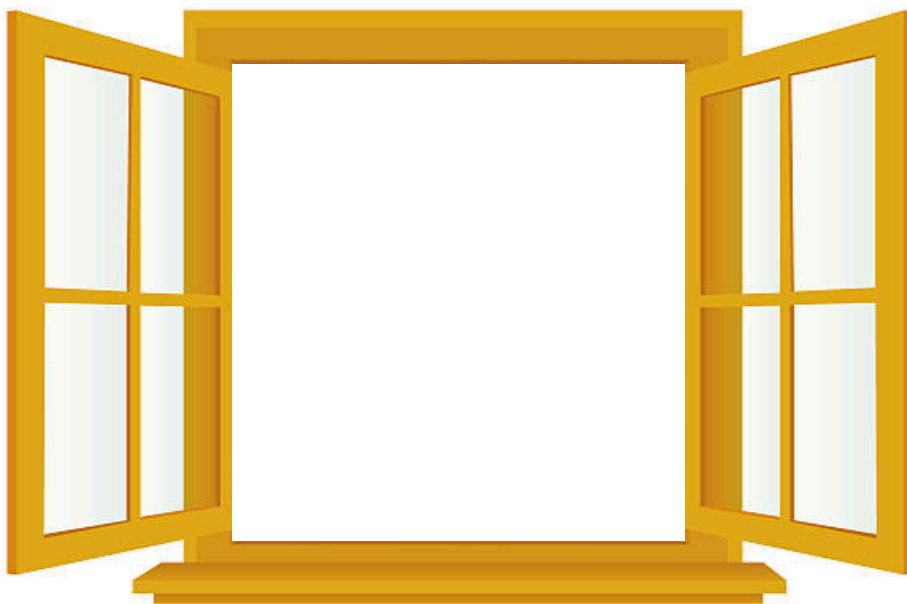

Good afternoon



3 Read and match.

1. Good morning



2. Hello!



3. Good afternoon



4. Goodbye!



5. Good evening





4 Now it's your turn to introduce yourself. Choose the letters of your name by coloring them from the box below.

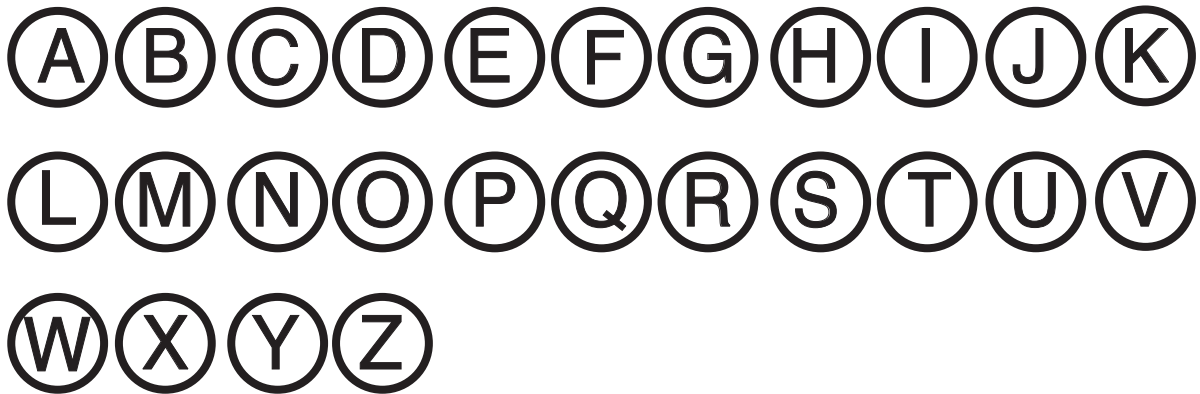

Hello!
My name is Jack.

Hello!
My name is

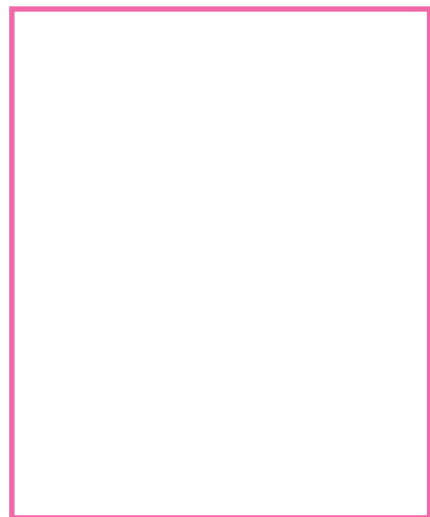



5 Order the dialogue and role play it.

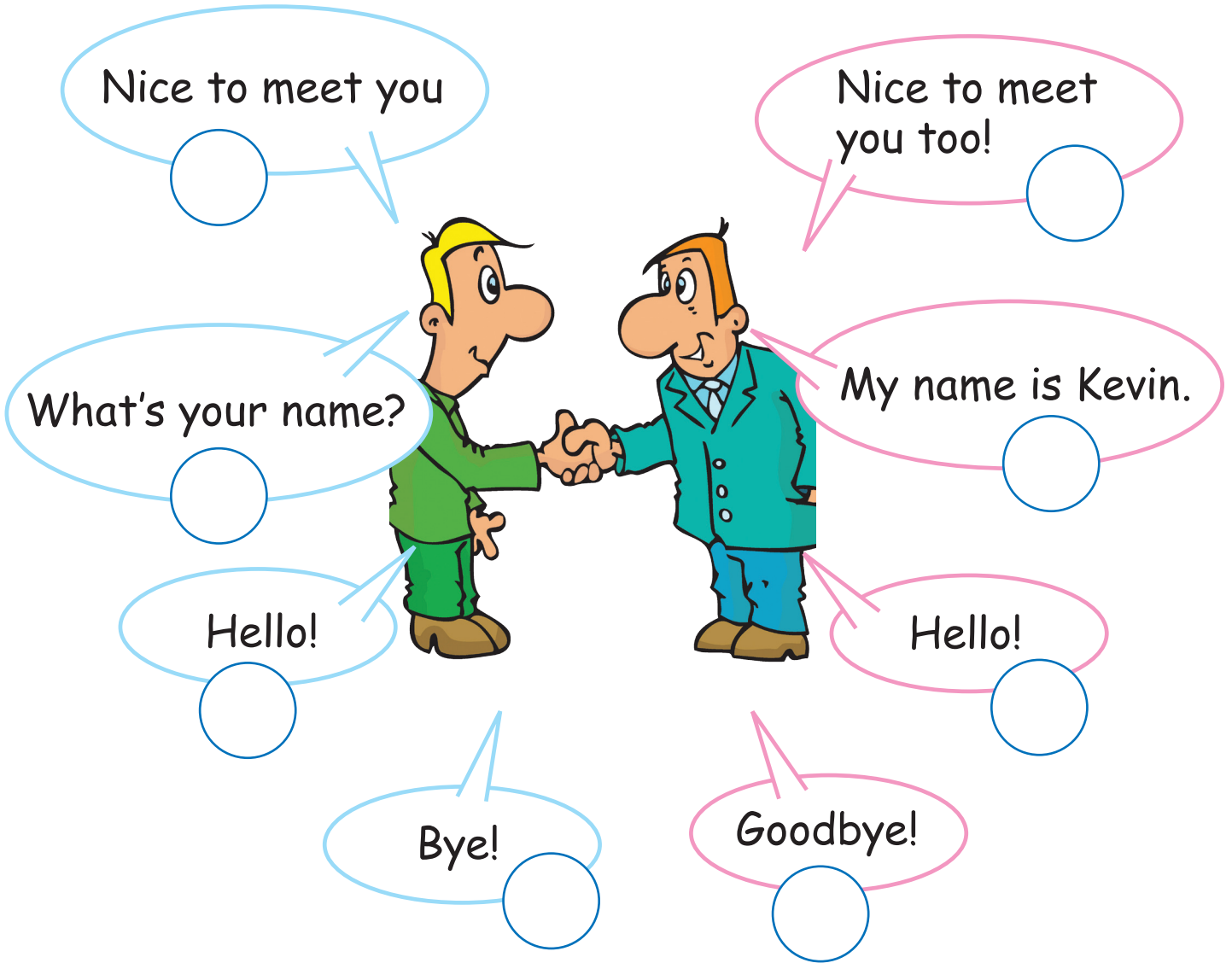

6 For teachers: Time to sing! Super English kid! How are you?

(Refer back to YouTube to hear this song).

The link is: <https://www.youtube.com/watch?v=4Du-AyqMNN4>

[v=4Du-AyqMNN4](https://www.youtube.com/watch?v=4Du-AyqMNN4)



1 Enjoy your time in class with your friends making this colourful spinner. Write the selected color each time on the line.



1.

4.

2.

5.

3.

6.



Target language: blue, green, orange, pink, purple, red, yellow..., balloon

Language structures: What color is it?; It's (color); It's a (color) (...).

Time: 10minutes

Materials: Inflated balloons of various shapes and colors

- First throw one of the balloons amongst the pupils, e.g. a red one: "It's red/it's a red balloon".
- Show the children that the balloon must not touch the ground.
- The children call out the color of the balloon "It's red/it's a red balloon" each time it falls to them.
- Then throw another colored balloon, e.g. blue "It's blue/it's a blue balloon".
- Now the children are passing around two balloons.
- A third balloon can be added, e.g. yellow "It's yellow/it's a yellow balloon."
- Then remove one of the balloons e.g. the red one, and replace it with a green one.
- Before the end of the activity throw all of the balloons you have in amongst the pupils and let them enjoy.

Note:

It is important to pay attention to children's safety (remind them not to jump out of their chairs to reach a balloon). It may be safer to play this game either in the gym or in the playground.





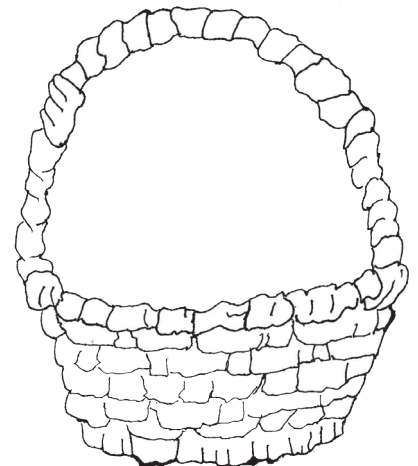
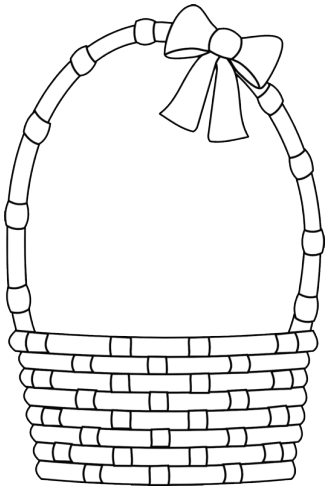
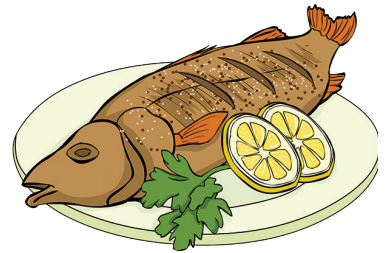
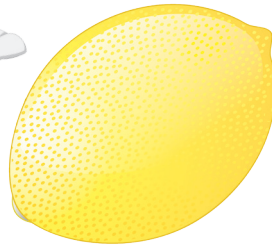
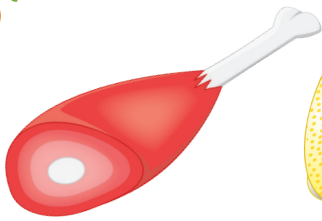
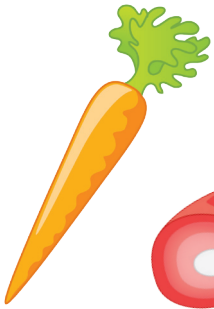
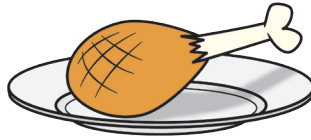



2 Put in groups.





3 Colour the numbers.

1		3		5		7		9	
2		4		6		8		10	

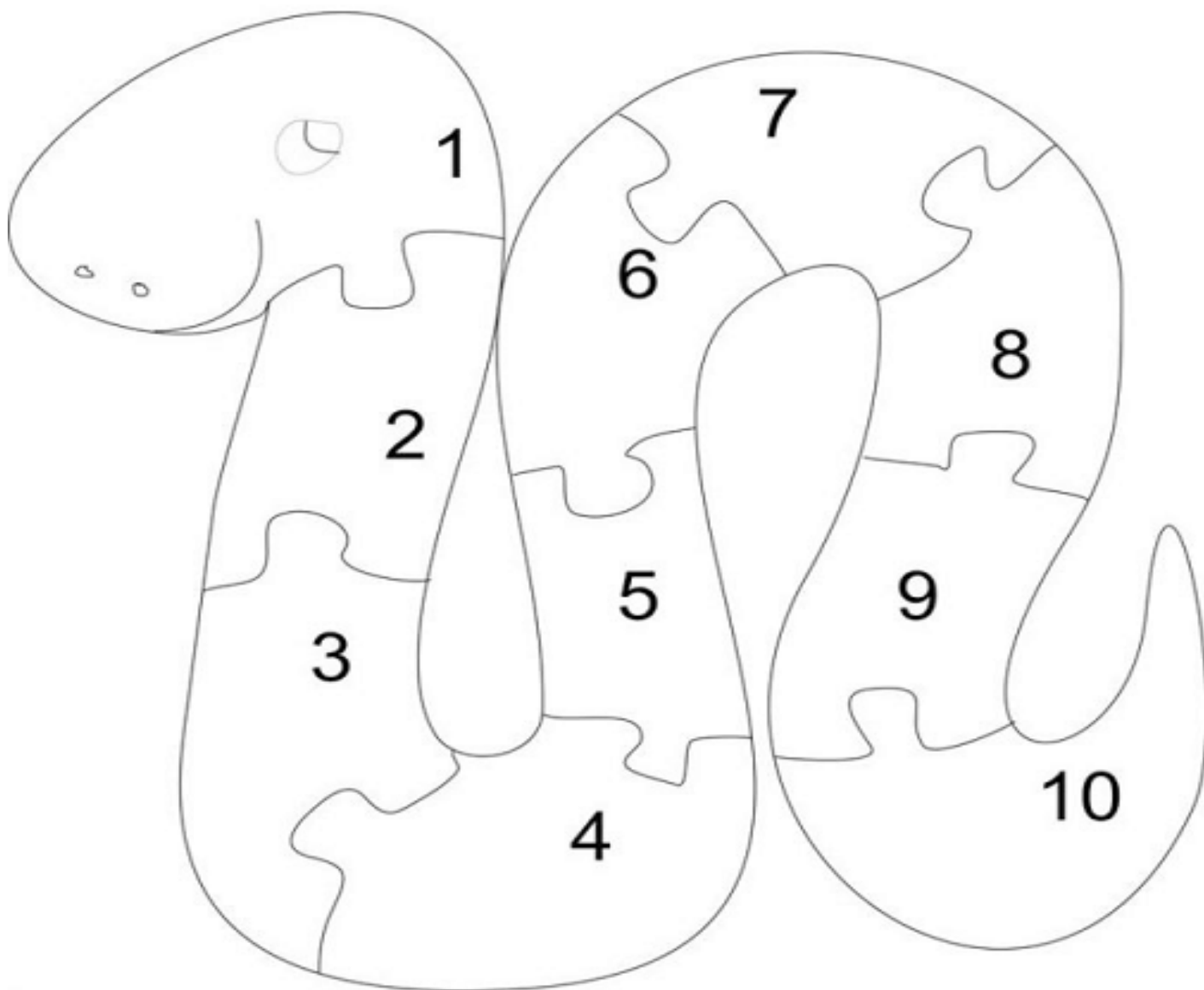



4 Use the sticky circles to number the arms of the octopus.
The first two steps are done for you.

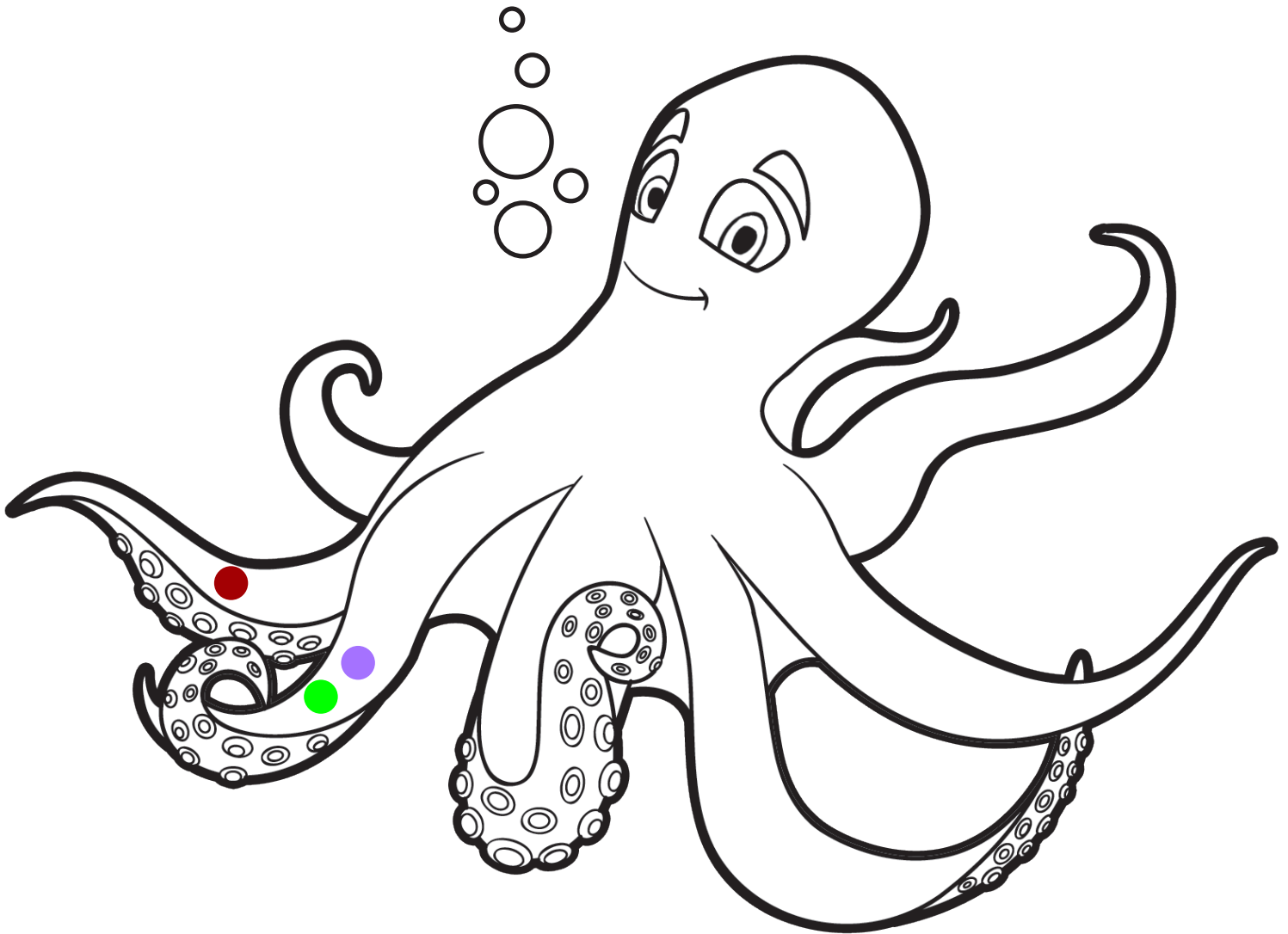

Note for teachers: students need sticky circles to finish this task.



5 Match each shadow with its picture.

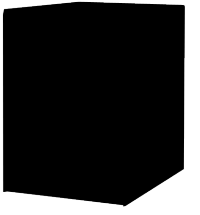
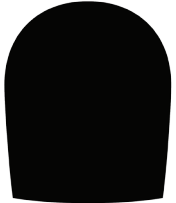
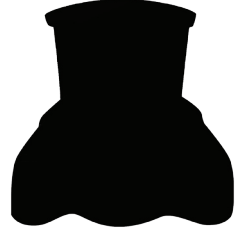
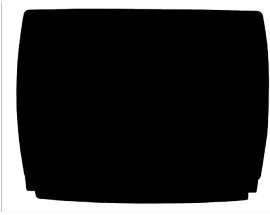



6 Write, ask and answer.

1. What is this?

It's

What colour is it?

It's

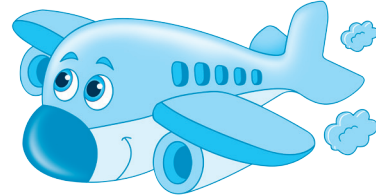

2. What is this?

It's an

What color is it?

It's



3. What is this?

It's a

What color is it?

It's and



4. What is this?

It's a

What color is it?

It's



5. What is this?

It's an

What color is it?

It's and





1 Do you know these body parts?

Is it a hand?



.....

Is it a nose?



.....

Is it a mouth?



.....

Is it a head?



.....

Is it an arm?



.....



1 Paste your family pictures in the right place.

FAMILY TREE

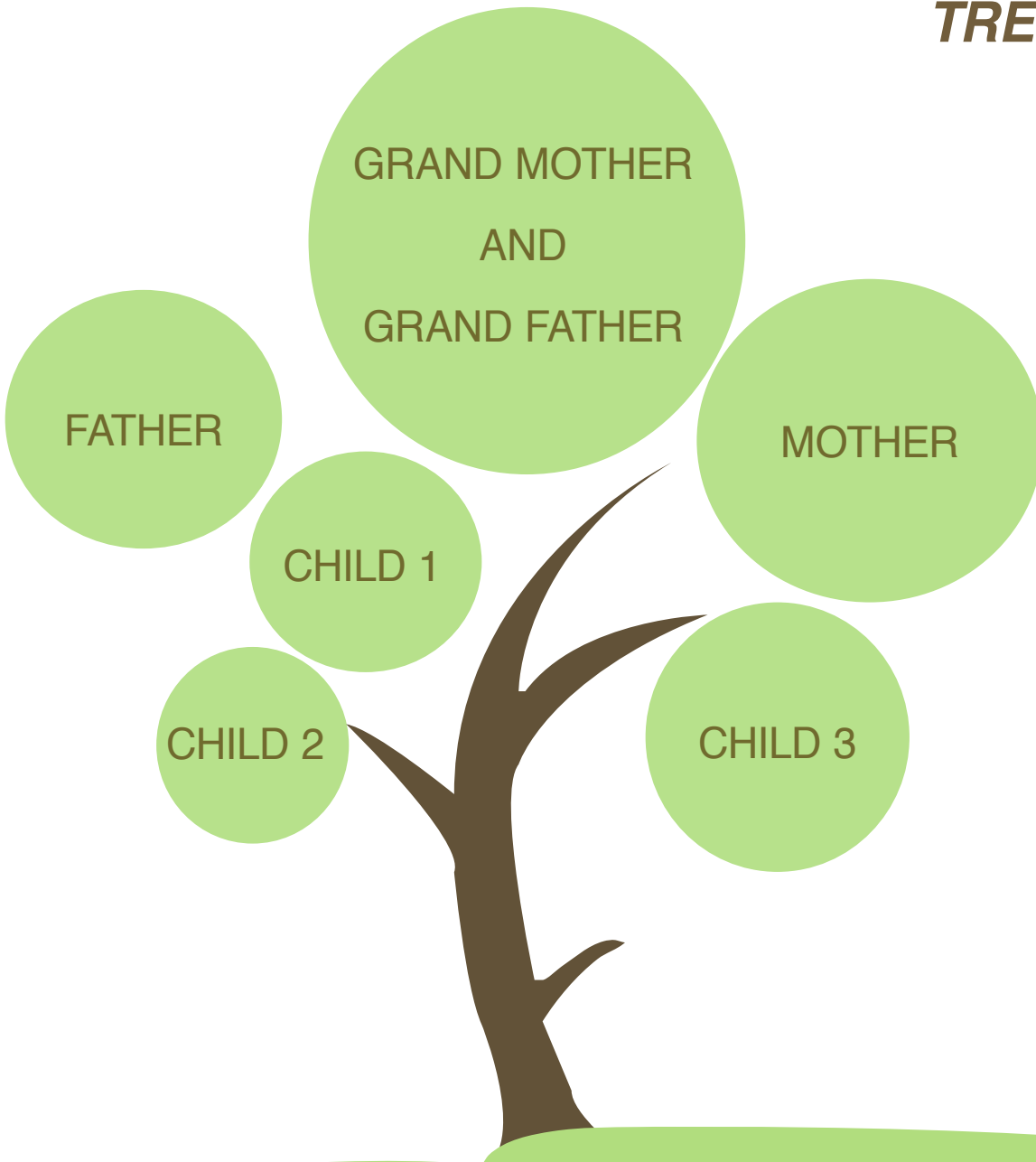



Guess whom I'm talking about.

Write the name under each picture.

My grandfather is wearing eyeglasses.

My mom has got blond hair .

My brother is wearing a cap.

My little sister is wearing a red skirt.

My grandmother has got white hair.

My father has got black hair.

Finally the one who is smiling g is me.

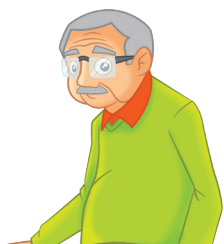
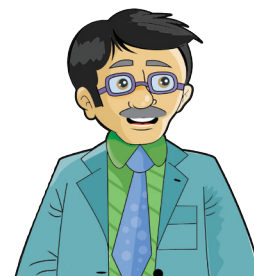



1 Count and circle.

6 11 4

2 7 4

7 3 4

4 3 5

1 3 5

7 3 1

9 8 11

10 8 9



2 Let's sing this nice song.

Number song 1-20 for children | Counting numbers | The Singing Walrus <https://www.youtube.com/watch?v=D0Ajq682yrA>

3 Draw an animal using number 9.

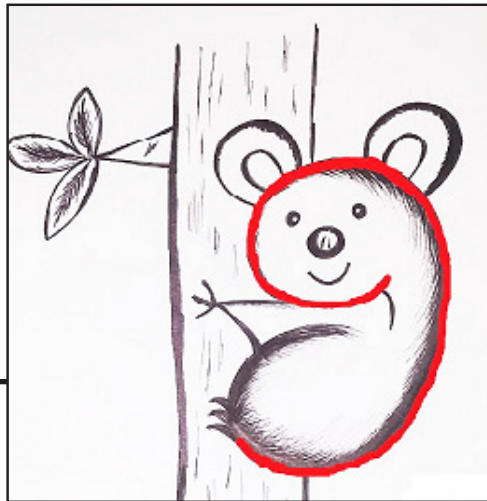

A large empty rectangular box for drawing.



4 Draw a bird using number 2.

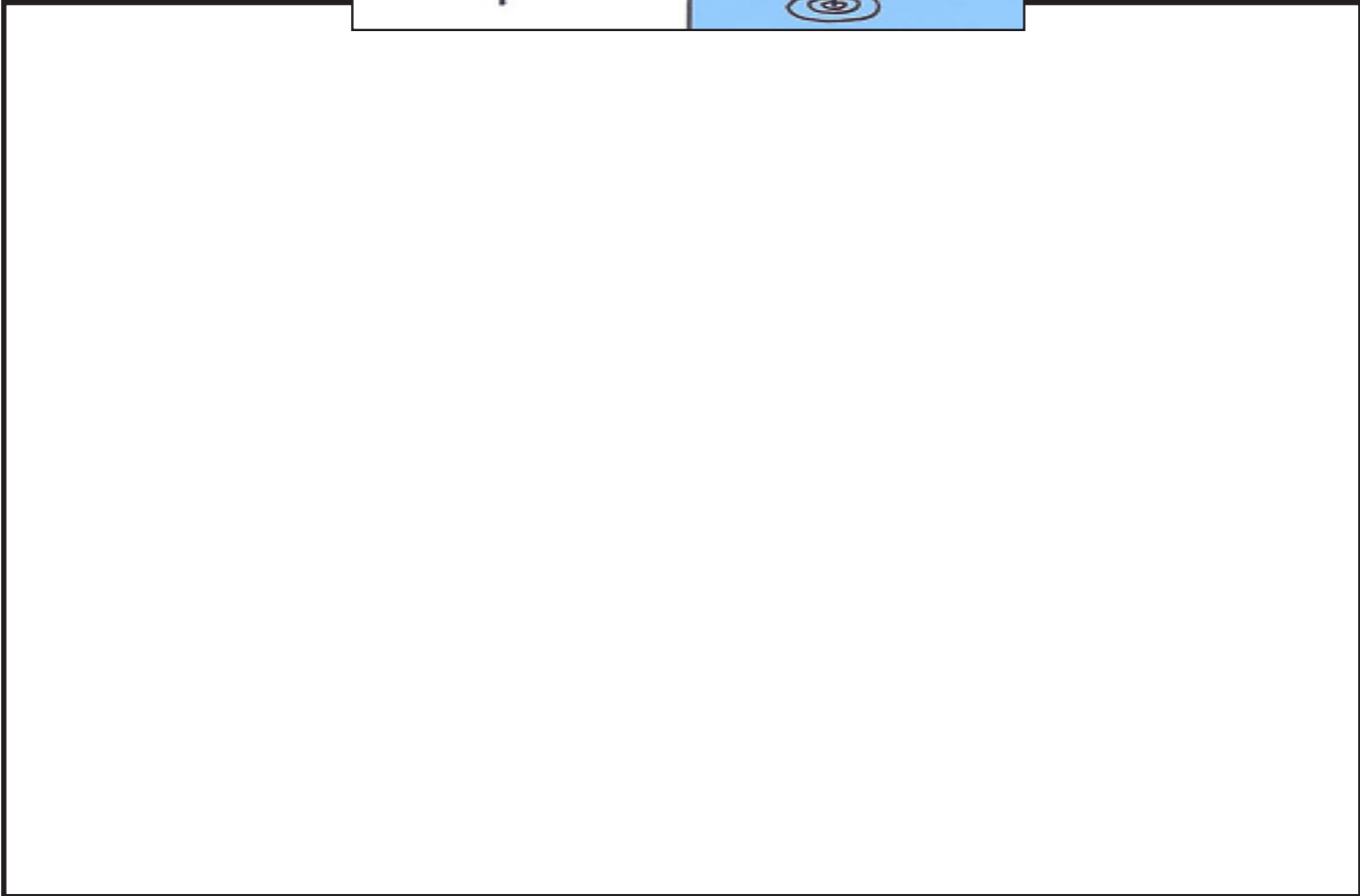
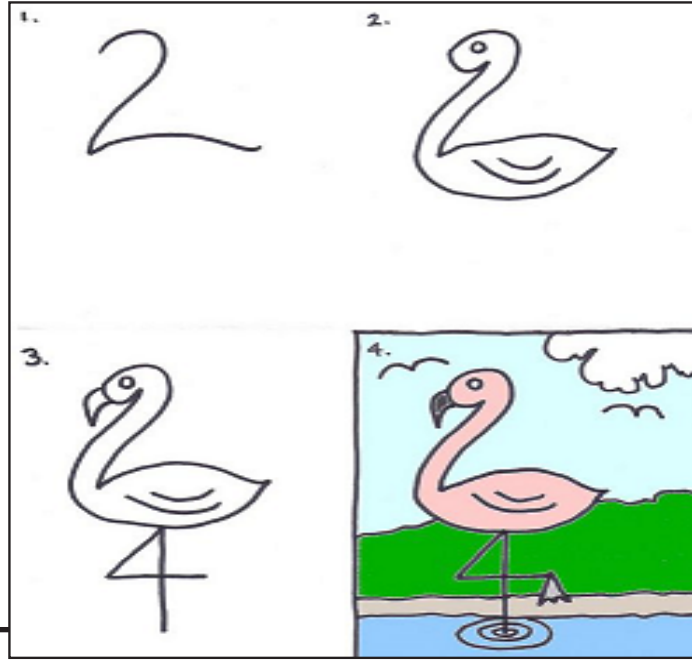



5 Draw an animal using number 5.

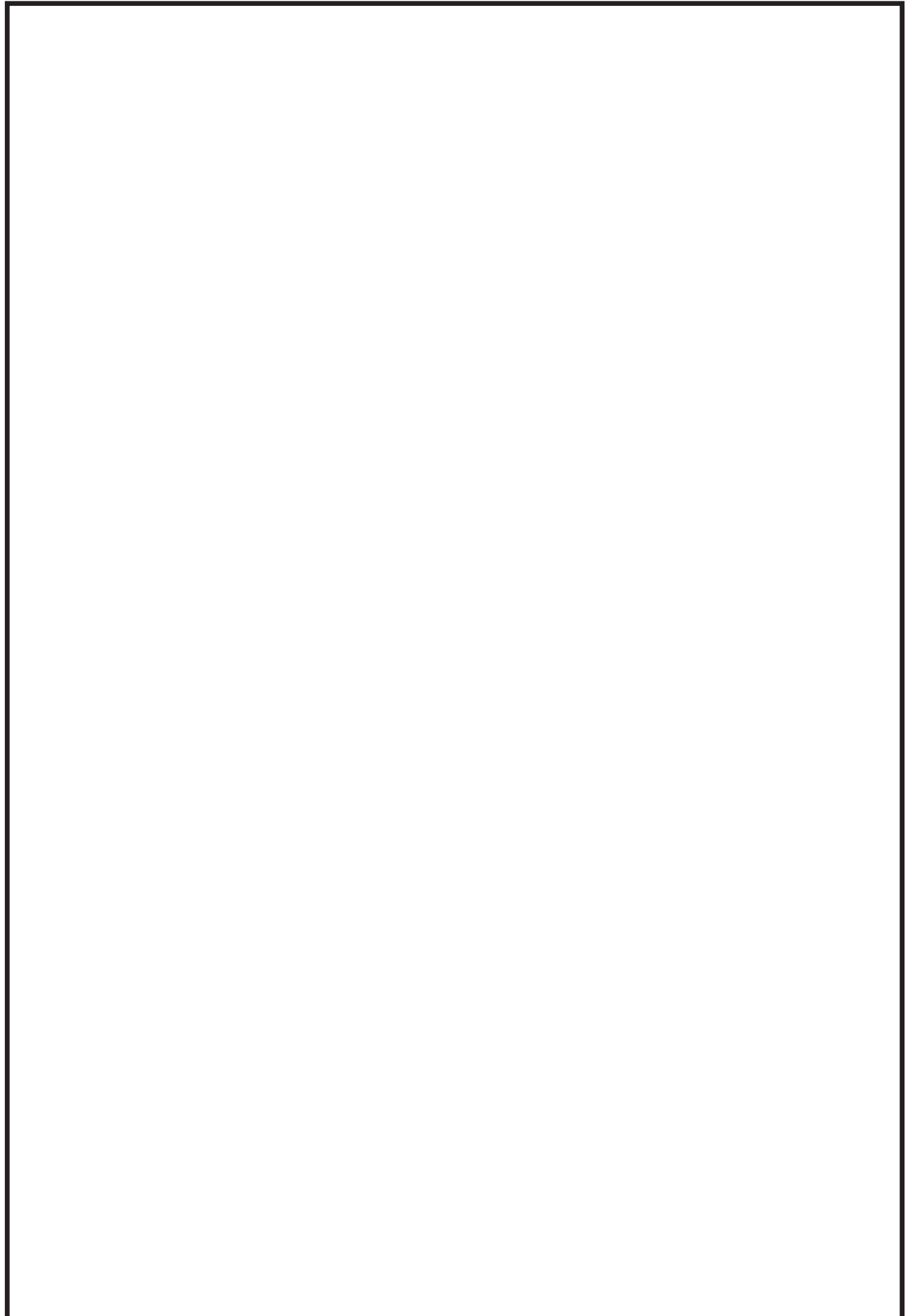



6 Draw an animal using number 8.





7 What do you think you can draw by using number one?

1



8 Spot the differences. Find 5 differences.

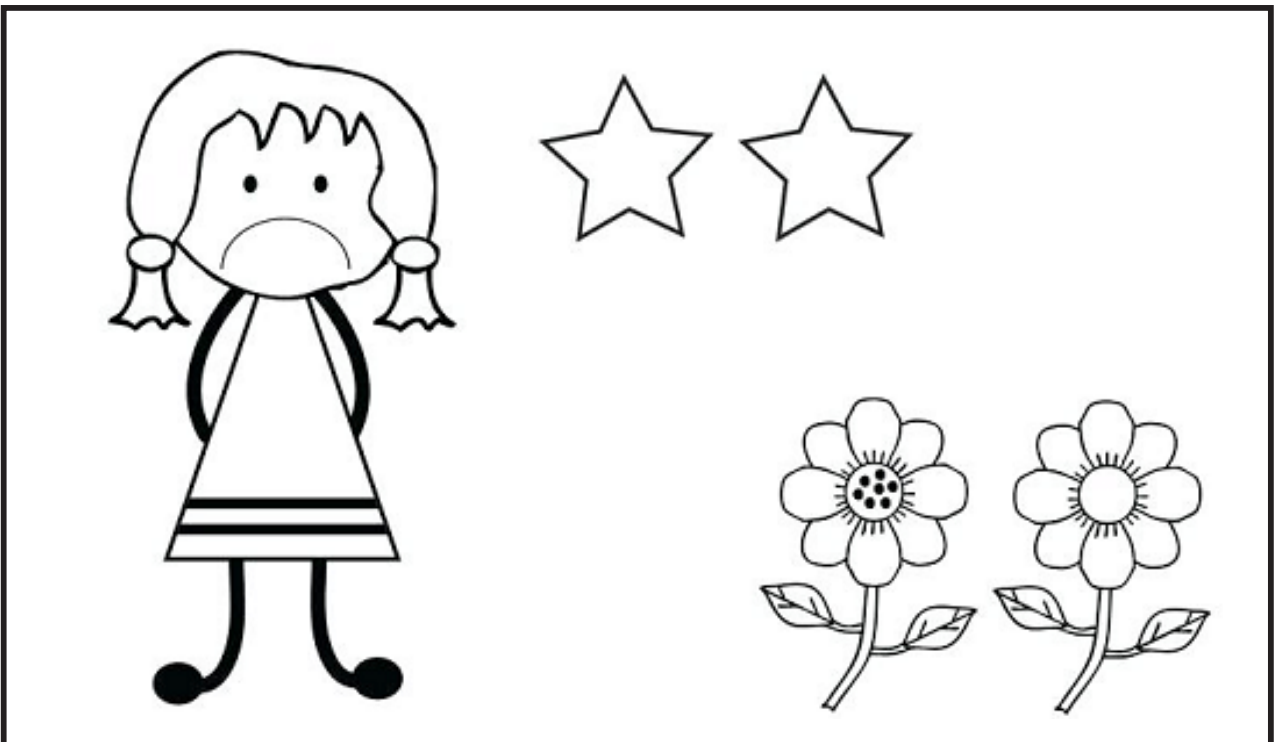
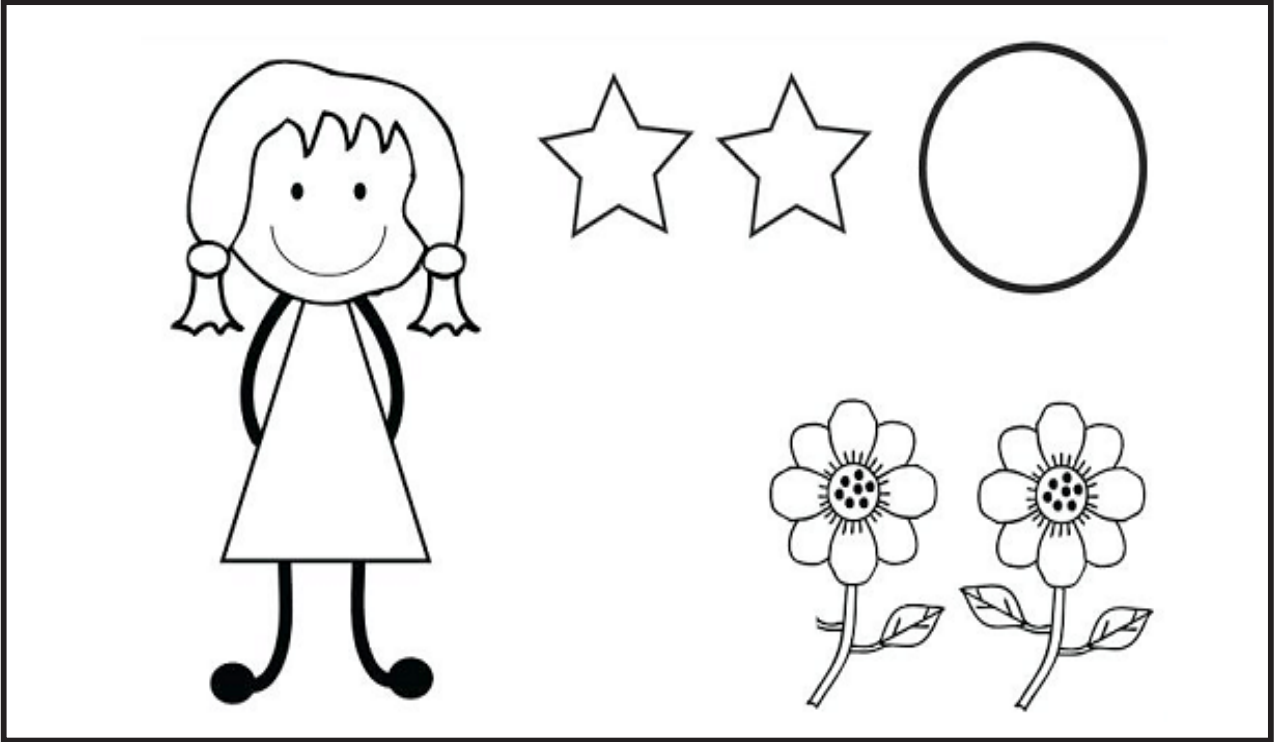



9 Choose a word from the box. Fill in the blanks and number the pictures.

hand / door / walk / name / run

- 1. Don't in the corridor!
- 2. Write your on the board.
- 3. Open the
- 4. Raise your
- 5. Don't on the grass.





10 Match the signs with the following command.

Don't cross the road!



Don't shout!



Open your book!



Don't smoke!





1 Use (This or These).



1. What are these?

..... are bats.



2. What is this?

..... a butterfly.



3. What are these?

..... forks.



4. What is this?

..... a bear.



2 Fill in the missing vowels (i,o,u,a,e) for each of the followings:

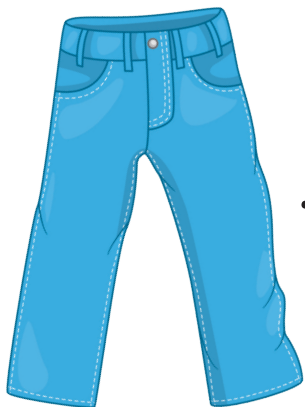

tr__s__rs



sl__pp__rs



sh__rts

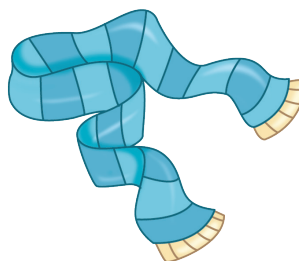

sc__rf



sk__rt



j__ck__t



3 Fill in the missing vowels (i,o,u,a,e) for each of the followings:



..... o o s



..... a



..... e



..... o a



..... o e



..... o



4 Classify your clothes into winter or summer clothes.

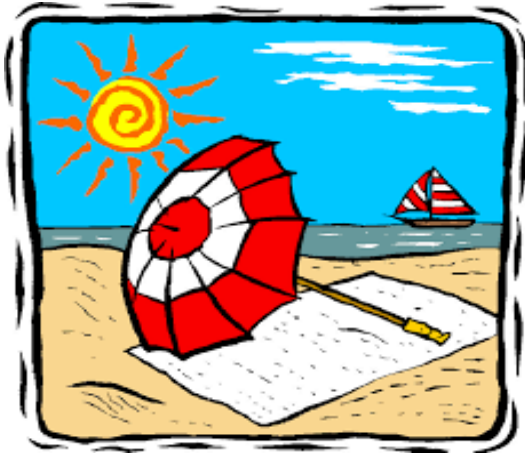

- 1.
- 2.
- 3.

- 1.
- 2.
- 3.
- 4.

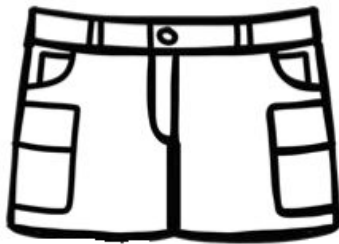



5 Math the clothes with the body parts they cover.



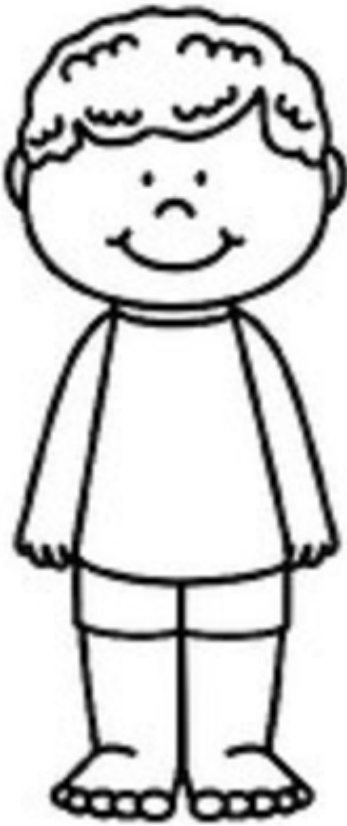



1 Reading is fun!
Fill in the arrows with the correct words.

axe / fire truck / fire Extinguisher / water / hose / bell

He's a firefighter.
These are his tools.

This is his



This is a



This is his

This is his

1 Match the sentences with the suitable pictures.

1. Let's plant a tree.



2. Let's pray together.



3. Let's help our mom.



4. Let's clean the garden.



5. Let's tidy the room.





1 Complete the sentences.

- yellow fingers.
- brown and green.
- small head.



Hi, I'm Mr. Rooster. I have a

I have two and wings.

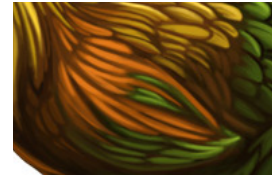

I have a tail.



I have three in each foot.

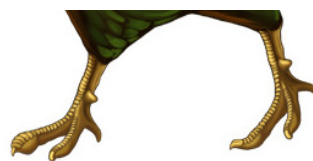



1 Guess whom we are talking about? Write the name under the picture.

- My name is Sally.
- I am seven, too.
- I have brown hair.
- I wear a blue dress with a star on it.
- My name is Amal.
- I'm seven.
- I have blond hair.



- My name is Jamil.
- I'm eight.
- I have black hair.
- I wear a T. shirt with green strips and red trousers.



1 Rewrite the following sentences using the possessive form. Draw.

1. This is the car of Ameer.

This is Ameer's car.

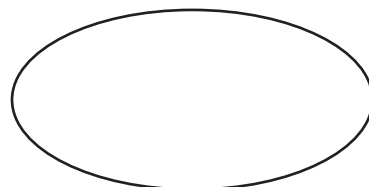

2. These pencils are for the girls.

These are the girl's pencils.



3. This boat is for the sailor.

.....

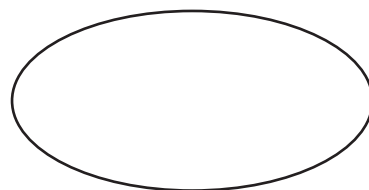

4. These shops are for the men.

.....

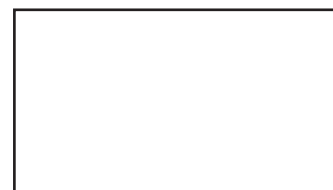

5. This ball is for Majd.

.....

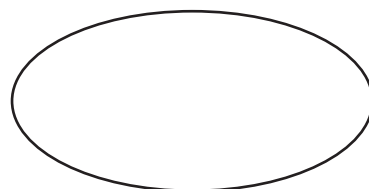



1 Paste a picture for your family members and choose the correct answer.

[Large empty rounded rectangle for pasting a picture]

- This my family. (is / are)
- I have (1,2,3,4) (brother/ brothers).
- I have (1,2,3,4) (sister / sisters).



2 Who are they.....? Look, read and complete the dialogue.



- Janna: Are these your neighbours?
Yasser: No, they aren't.
- They are my
- Janna: How many brothers and sisters do you have?
- Yasser: I have two
brothers and one



1 Home Appliance. Which picture is different?

Something is missing from one picture in each row. Name the picture and draw a circle around the different one. (table, arm chair, lamp)

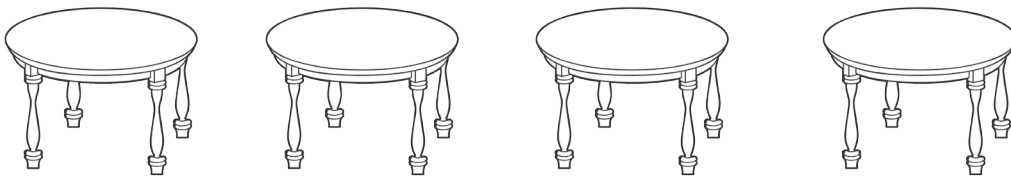

.....

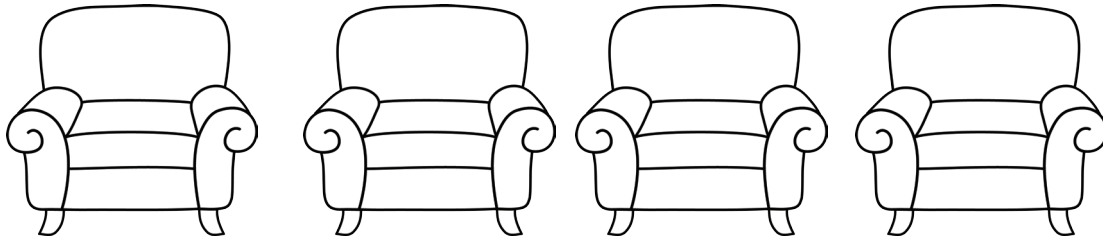

.....

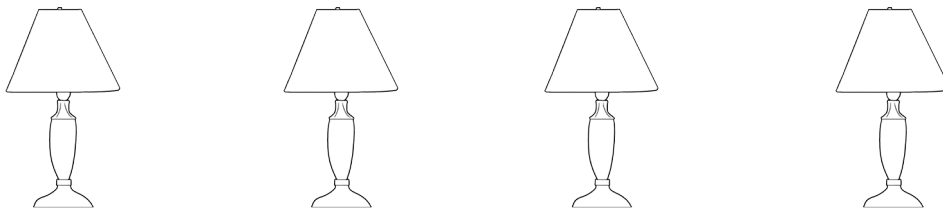

.....

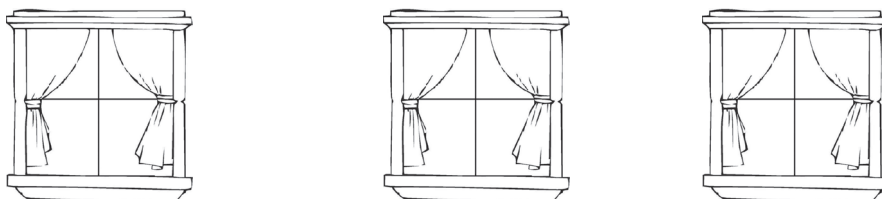

.....



2 Where can you find these items. Match them with the appropriate room or place.



Living room



Kitchen





3 Cut and paste the stickers on the suitable shadow.

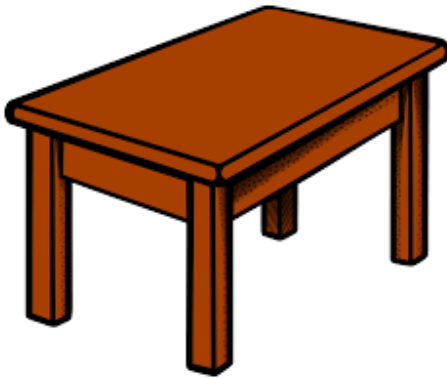









Grade 1

Unit

17

Extensive

Student's Name.....

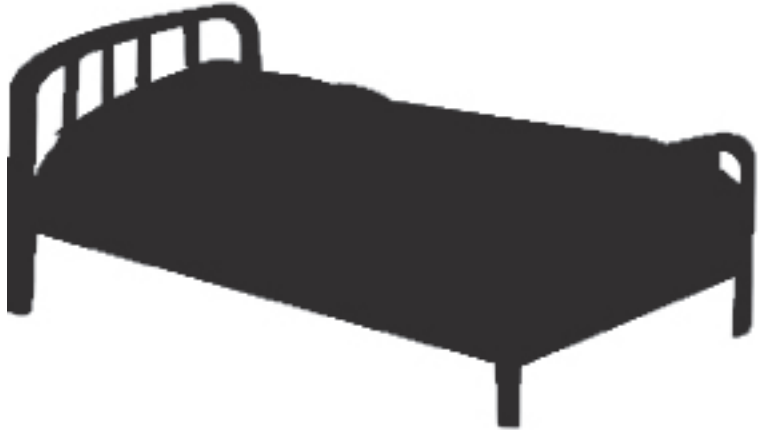



4 Prepositions of place.

on / in / under

- In the winter I wear a hat my head.
- I put my sandwiches the lunch box.
- My cat sleeps my bed.
- We keep food the fridge.
- I dropped my pencil the desk.

5 Look and answer.

- Where is the plant?

The plant is the pot.

- Where is the radio?

The radio is the shelf.

- Where are the toys?

The toys are the desk.

- Where are the shelves?

The shelves are the wall.

- Where is the rug?

The rug is the floor.

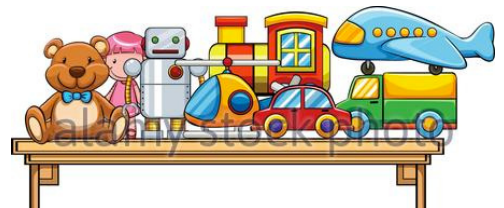



1 What is the time?
Let's make our own clock.

1. Draw a circle.
2. Paste numbers (1,2,3-----12) on the correct spot.
3. Cut small rectangles to create two black hands for hours and minutes and a red one to illustrate seconds.
4. Fix the hands in the middle with a special pin.

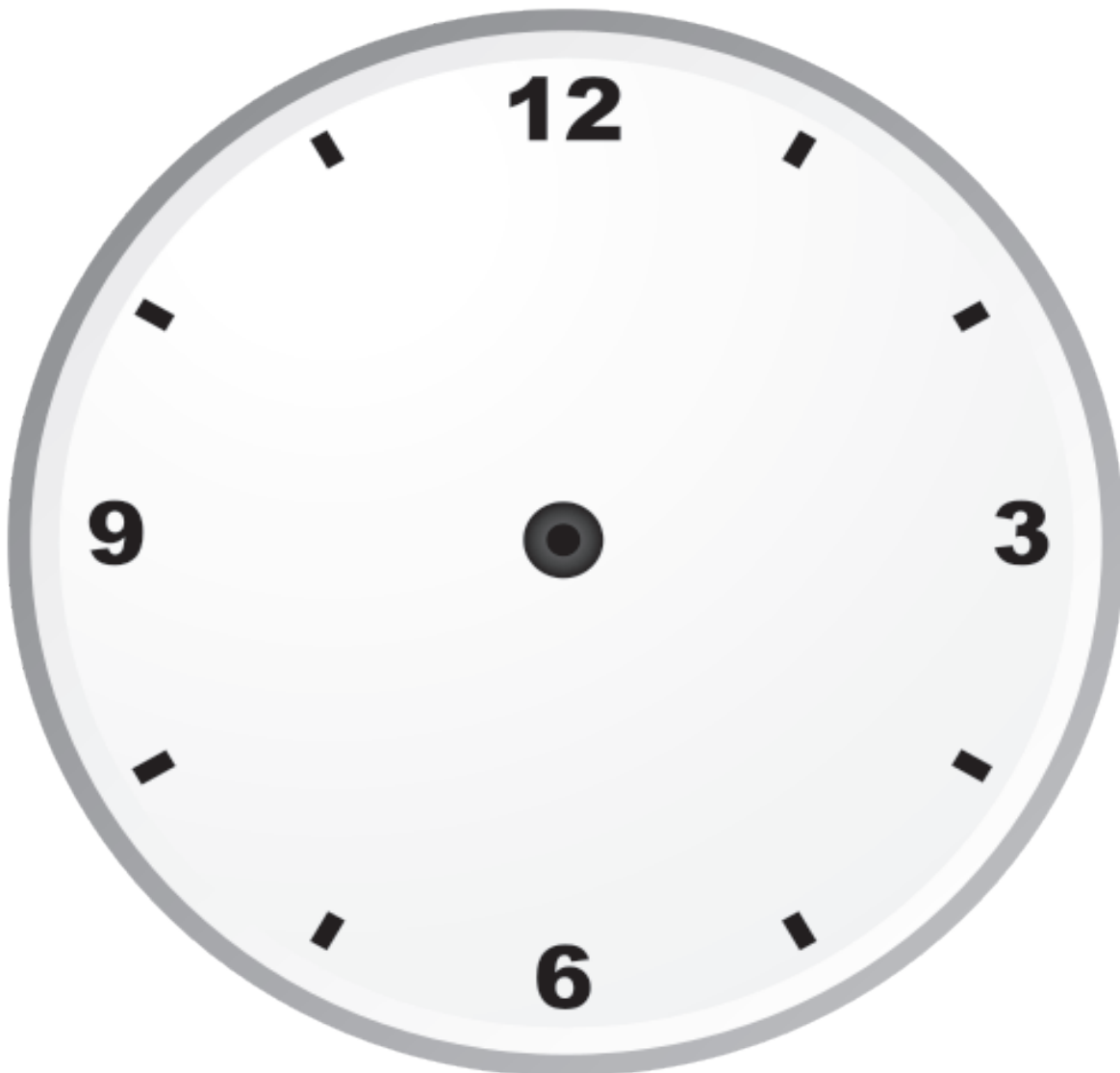



2 Draw the two hands of the clock to show the correct time.

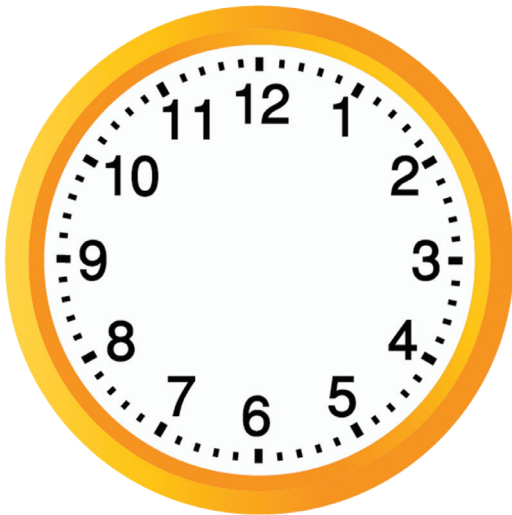

1. What time is it?
It's twelve o'clock.

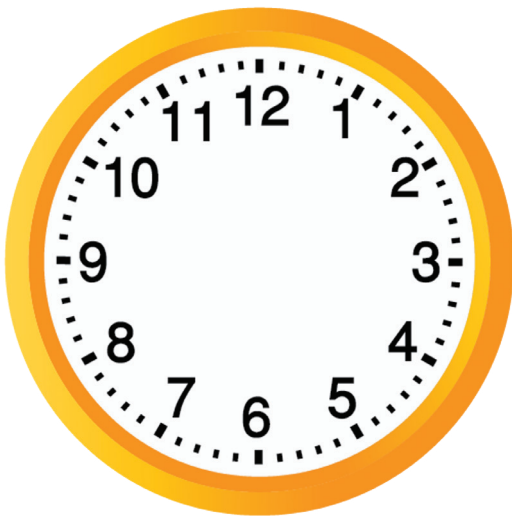

2. What time is it?
It's half past two.

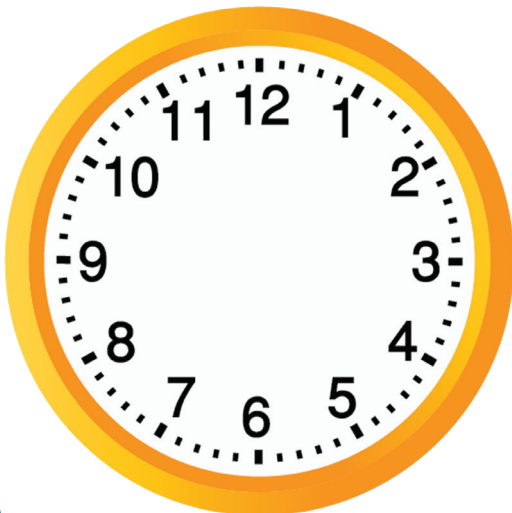

3. What time is it?
It's half past ten.

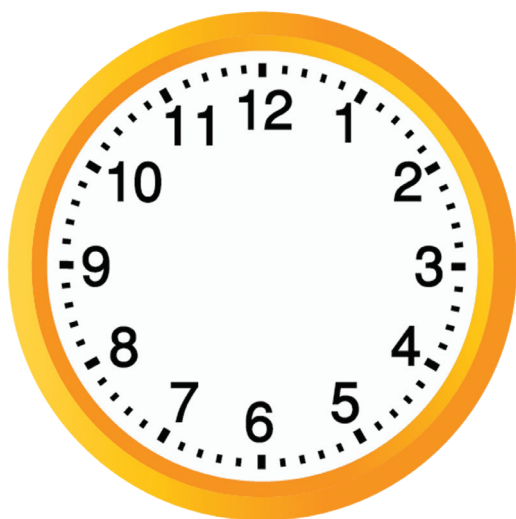

4. What time is it?
It's six o'clock.

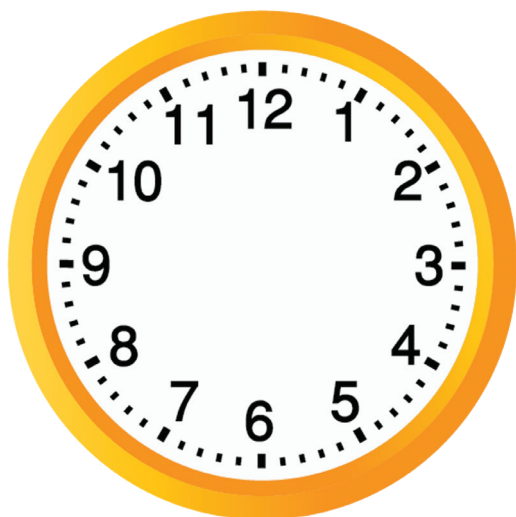

5. What time is it?
It's eight o'clock.



1 Tick the correct answer.



This is

- soft
- clean
- dirty



This is

- hot
- cold
- icy



This is

- fast
- old
- young



These are

- small
- big
- fast

2 Color the following pictures and write three adjectives to describe each one. Be creative!

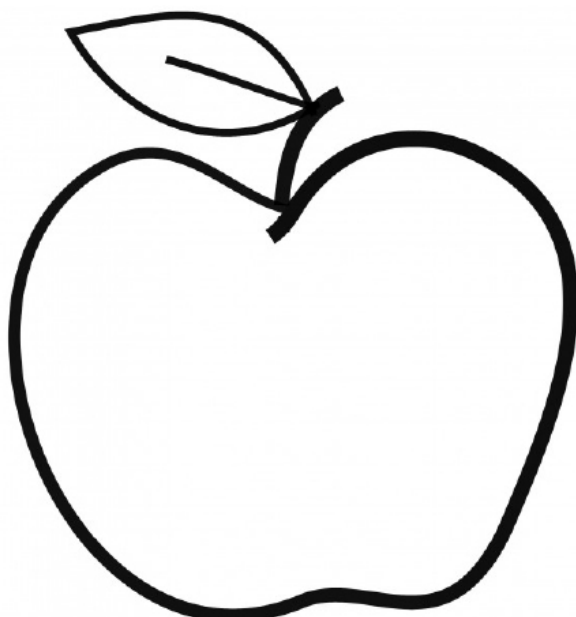

This is an apple.
It's big.
It's red.



Student's Name.....



.....
.....
.....

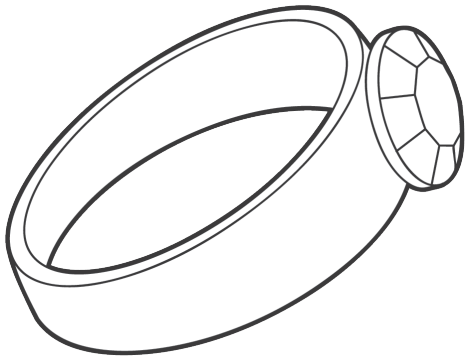

.....
.....
.....

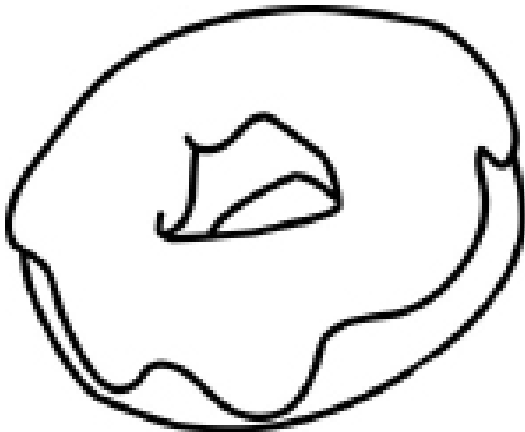

.....
.....
.....



3 Write the opposites for the following adjectives. Use the ones in the box.

small / ugly / sad / near / short

1. big

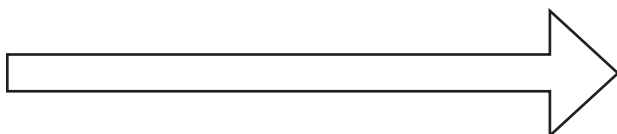

.....

2. happy

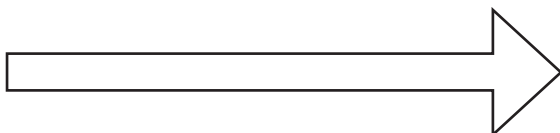

.....

3. far

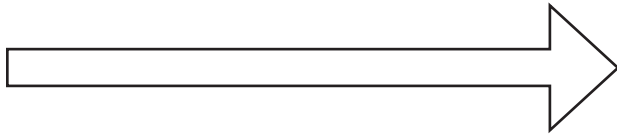

.....

4. tall

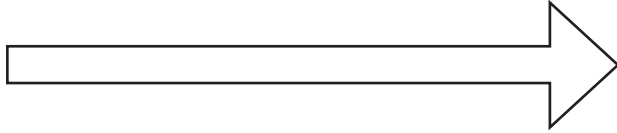

.....

5. beautiful

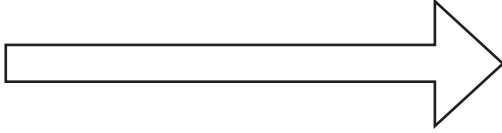

.....



1 Match these drinks with the correct pictures.

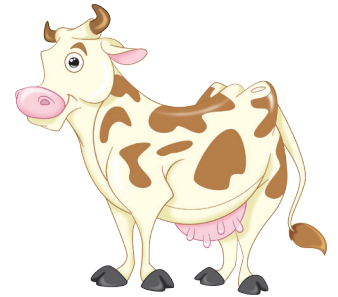
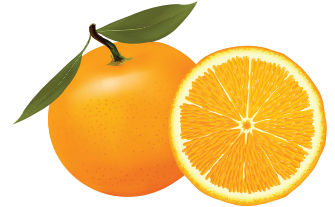

2 Complete the dialogue.

- I'm thirsty. I would like a cup of (tea, sandwich).
- Would you like to (drink, eat) some tea?
- I'm (hungry, thirsty). I would like some water.
- It's hot outside. Would you like something (cold, warm) to drink.



1 Fill in the missing letters.

1. Butterflies are be - uti - ul.



2. Parrots are colo - rf - l.



3. Cats are c - te.



4. Tigers are f - st.



5. Turtles are sl - w.

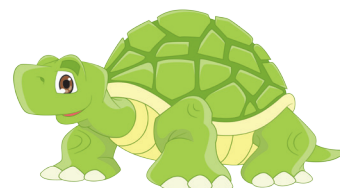



1 Rewrite these sentences in the plural form.

There is a fox in the box.

There are foxes

There is a bear on the chair.

.....

There is a bee under key.

.....

There is a bat on the hat.

.....

There is a snake behind the cake.

.....

.....

2 Describe the room using there is and there are.

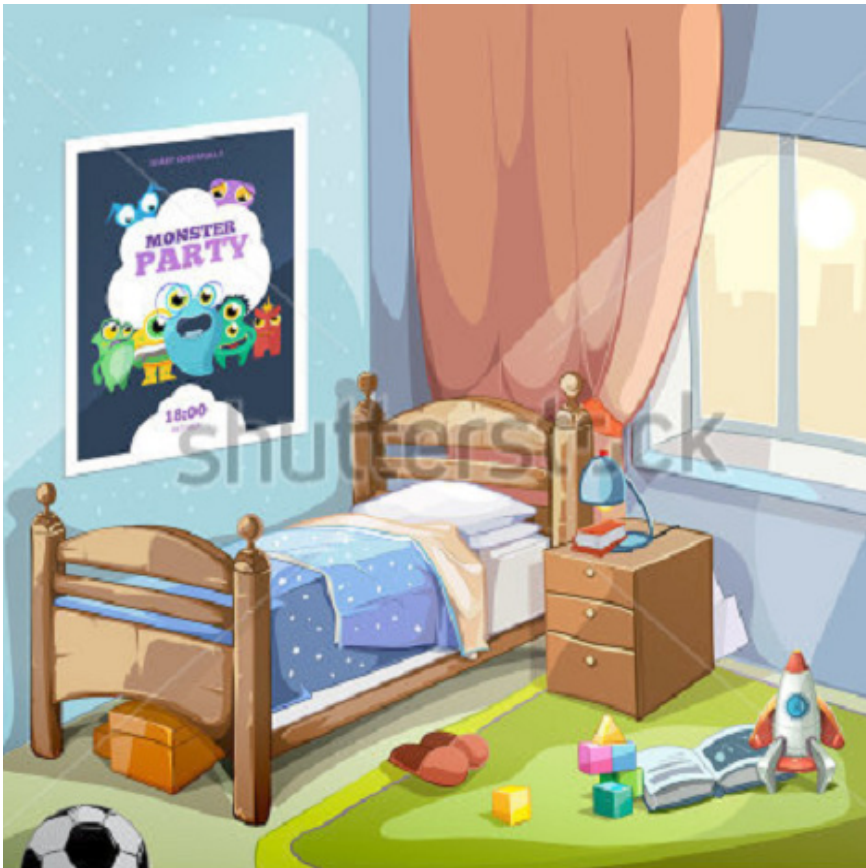

There is a

There are

There is

There are

1 Colour, ask and write.

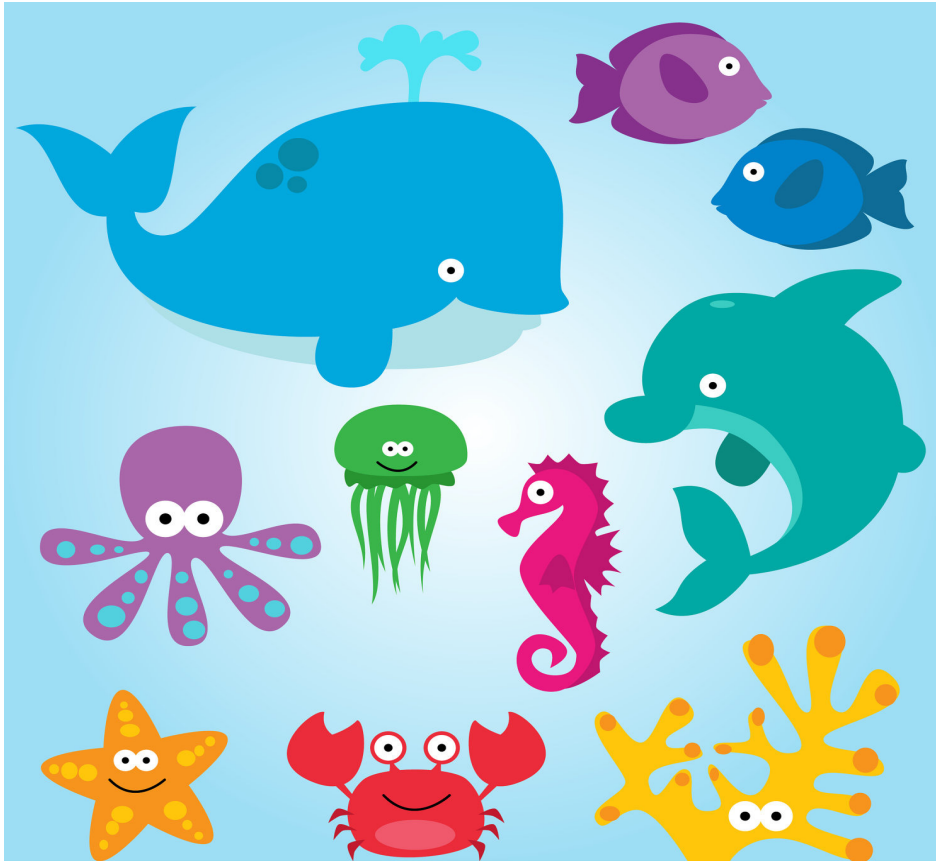

1. Is there a shark?

Yes,

2. Are there sea horses?

No,

3. Is there an octopus?

.....

4. Are there frogs?

.....

5. Is there a boat?

.....



1 Match, ask and answer.

Where is the chef?



Where is the mechanic?



Where is the football player?

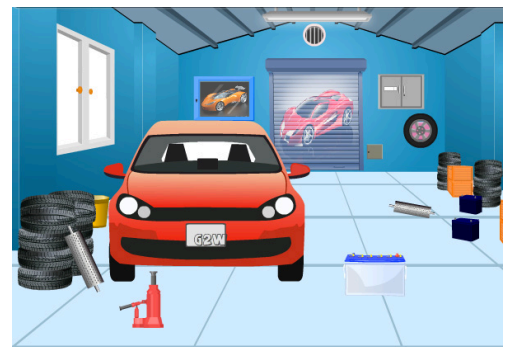



1 Can or can't.



A parrot (can, can't) sing.



A dog (can, Can't) smell very well.



A snake (can, can't) run or walk.

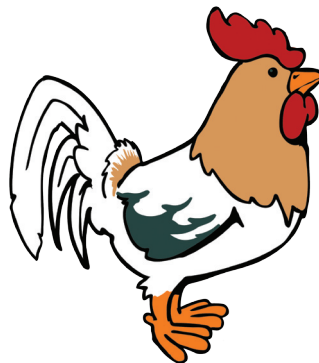

A rooster (can, can't) give you eggs.

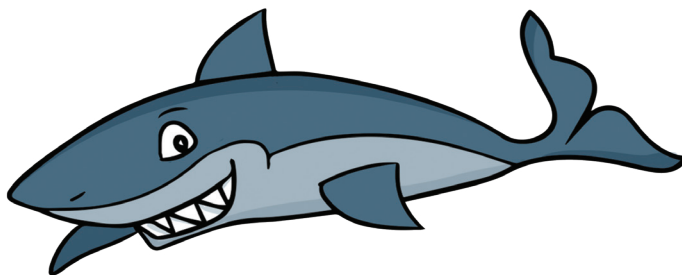

A shark (can, can't) swim fast.



1 Put a green tick for can and a red cross for can't.

	run fast	fly	sing well	ride a bike	play the piano
	<input type="checkbox"/>	<input checked="" type="checkbox"/>	<input type="checkbox"/>	<input checked="" type="checkbox"/>	<input type="checkbox"/>
	<input type="checkbox"/>	<input type="checkbox"/>	<input checked="" type="checkbox"/>	<input type="checkbox"/>	<input checked="" type="checkbox"/>
	<input type="checkbox"/>	<input type="checkbox"/>	<input type="checkbox"/>	<input checked="" type="checkbox"/>	<input checked="" type="checkbox"/>
	<input checked="" type="checkbox"/>	<input checked="" type="checkbox"/>	<input type="checkbox"/>	<input type="checkbox"/>	<input type="checkbox"/>

Write about yourself.

- My name is
- I can and
- But I can't or



1 Present continuous. What are they doing?



He is a shower.



He is a bicycle.



She is a book.



She is ice cream.

What are you doing?

I'm

1 Put a circle around the one whom we are talking about.



The boy with the orange hat is running.

They are drinking hot chocolate.

The man with the red coat is fishing.

The snowman is sliding.

What are the others doing?





1 Colour the circle with the red if the used preposition is wrong, then write the correct one on the line.

1. My dad is on the kitchen.

.....

2. I always play behind my friends.

.....

3. Suzan: Where were you Amal?

Amal: I was at school.

.....

Suzan: Did you play there basketball?

Amal: Yes, I did. I played under rain, it was funny.

.....

4. Where do you work Mr. Yasser?

I work under a hospital.

.....



1 Match the pictures with the correct preposition and place.



in

Pool



at

School



With

Kitchen



Friends